

BFI Network Present



# *new atlantis*

A VIDEOfeet production in association with CROWBLACK FILMS



THE NATIONAL  
LOTTERY®



NETWORK

# ***new atlantis***

## ***CONTENTS***

1. LOGLINE
2. SYNOPSIS
3. ABOUT NEW ATLANTIS
4. CHARACTER LOGLINE
5. ABOUT VIDEOFEET
6. CAST AND CREW
7. CAST BIOGRAPHIES
8. CREATIVE BIOGRAPHIES
9. PROCESS
10. FESTIVAL RECOGNITION (PREVIOUS WORK)
11. TECHNICAL INFORMATION
12. ASSETS AND CONTACT



*PHOTO: KATIE SMALE*

# ***new atlantis***

## ***LOGLINE***

While exploring an abandoned building, two friends discover a recording of a woman who claims to be the last citizen of a lost Utopia.



***PHOTO: KATIE SMALE & BENJAMIN ALUWIHARE***

## **SYNOPSIS**

Jess and Chris are best friends who live in a nowhere motorway town on the edge of the M25. They're poor; trapped by their circumstances with no hope or dreams for the future.

After an illegal rave at an industrial unit they break into one of the abandoned buildings nearby. They creep through its crumbling rooms transfixed by the building's decay. Its rusting surfaces, forgotten objects and flaking, peeling paint. They discover old journals, artworks, vibrant plants and finally an old cassette player.

Then everything changes. The player has a cassette with a recording on it. A recording of a woman who claims to be the last citizen of a lost utopia.

*NEW ATLANTIS* was inspired in part by Sir Francis Bacon's 1626 unfinished novella of the same name and asks us to imagine a world beyond our protagonist's current reality.

**PHOTO: ALLER PARK, DARTINGTON**

When filming a series of artist films in abandoned places in France, Matt had the strange experience of finding a cassette tape which had a recording of the man who had lived in the building, giving a speech to UNESCO. It was introduced in English so the sudden feeling of direct conversation with the deceased owner of the crumbling building he was in was bizarre and frankly unsettling. It definitely sparked something, some sort of starting point for a film. Matt put it to the back of his head until stumbling on *New Atlantis* by Sir Francis Bacon about this mysterious hidden Utopia, 'Bensalem', sparking ideas about finding something like this in an abandoned space - hidden, mysterious, bizarre.

Matt loved the idea of these two friends exploring this crumbling, derelict building only to be confronted with an unexpected fear. Exploring old buildings was something he did as a teenager, and was seen as a rite of passage for many of his peers. Matt always found these buildings utterly terrifying, and would rarely get much further than the first doorway. He admired the adventurous spirit of his friends who would explore these buildings for hours, and can remember imagining what it would be like if he never saw them again. Would the building eat them up - or was there a monster lurking in the dark?

## ***ABOUT NEW ATLANTIS***

***PHOTO: DAIRY CREST SITE, TOTNES***

# ***CHARACTER LOGLINE***

## ***JESS***

White, British from a working-class background. A party-loving 18-year-old, who hates authority. She is fiercely intelligent but feels out of place in a world she considers to be inherently unfair and set against her and the people in her position. A lot of her friends are moving away but she can't afford to, and like Chris has nowhere to go.

## ***CHRIS***

Mixed Heritage/Black, British from a working-class background. Lives on the same street as Jess and is in the same year at school. Party loving and mischievous. Completely disenfranchised by the world around him and thinks little of his future or how his actions may affect it. He's fiercely protective of Jess as if she is a sister and will follow her anywhere. He often finds himself in trouble because of this.

***PHOTO: BENJAMIN ALUWIHARE & MATT SMITH***



# ***ABOUT VIDEOFEET***

VIDEOfeet are husband and wife team Rhian and Matt Smith who met at Dartington College of Arts (UK) in the early 2000s on graduating they began to create experimental low-budget shorts on Mini-DV often blending a dark sense of humour with societal observations. After successful runs at international Film Festivals, VIDEOfeet successfully applied for Art Council England funding for several R&D projects exploring the line between live performance and film.

With showcases at RICH MIX, TRESTLE ARTS BASE and the HORSE HOSPITAL this work lead to an ongoing collaboration with OBRA Theatre Company and a 5-year series of work entitled EX\_SITU resulting in 10 moving image pieces alongside exhibition and heritage responses screened in France at Ciné 32, Centre d'Art et Photographie (Lecture) and Le Théâtre Jacques Coeur among others. Several of these works were also selected for the London Short Film Festival and Aestica Film Festival (UK).

VIDEOfeet's approach to filmmaking is rooted in collaboration, using small teams and taking full creative responsibility for production and costume design, sound design, score, and practical effects. This approach was born out of the arts practice they developed at university, coupled with financial restraints from coming from low-income backgrounds with no access to traditional funding methods.

This unique working style has allowed them to create a safe and inclusive space on set while ensuring creative integrity and environmentally sustainable productions. Over the last 15 years, they have honed their approach to filmmaking outside of traditional preconceived notions of how sets operate, enabling them to discover new ways of working in film.



# CAST & CREW

Jess: Katie Smale

Chris: Benjamin Aluwihare

Alice Barnham: Alana Ramsey

William Rawley: Oliviero Papi

Ravers:

Ose Hayble

Lily Hughes

Mariona Horne-Batet

Joe Martin

Rose O

Citea Petronela-Elisa

Tallulah Rogowski-Lane

Bob Wright

Muneerah Yate

Written and Directed by Matt Smith

Produced by Rhian Smith

For BFI NETWORK

Executive Producer: Thomas Wightman

Project Coordinator: Niamh Coogan

Director of Photography: Matt Smith

Assistant Director

and Sound Recordist: Simon Clode

Camera Operator and

Aerial Cinematographer: Joby Newson

Gaffer: Matt Baxter

Production Design: Rhian Smith

Production Assistant: James Christian

Post Production: VIDEOfeet

Visual Effects Supervisor: Richard Reed

Original Score: Alex Hyland, Matt Smith  
and Keir Vine

Sound Design: Nick Davies and Matt Smith

Dubbing Mixer: Nick Davies

**PHOTO: KATIE SMALE & BENJAMIN ALUWIHARE**



## ***CAST BIOGRAPHIES***

### ***Katie Smale (Jess)***

Katie graduated from RADA in 2019 and then went on to be in Kenneth Branagh's "Death on the Nile". She recently played the lead "Samantha" in the one woman show "Army Girl" and "Leah" in the short film "Exposed" which was officially selected for the LA Student Film festival 2020.

Other short film credits include "Squirrel" and "Mirror Mirror". Alongside acting, Katie writes lyrics and session sings for production music companies. She writes regularly and edits both scripts and lyrics. Katie is the captain of the football team Sutton United Reserves. Katie is very excited to be making her BFI debut with NEW ATLANTIS.

### ***Benjamin Aluwihare (Chris)***

Benjamin graduated from Drama Centre London in 2019. His theatre credits include: Frantic Assembly's Fatherland (Lyric Hammersmith), The Tempest and A Midsummer Night's Dream (Guildford Shakespeare Company), Flinch (Pleasance London) and Afterglow (Waterloo East Theatre). His short film credits include: We Came Here to Dance (Nowness) and 3 Women (Tom Shkolnik).

He is thrilled to be making his BFI debut in Matt Smith's NEW ATLANTIS. Beyond acting, Benjamin is a writer and DJ. He hosts a monthly radio show on Hackney's Netil Radio under the name benjaluwi.

**PHOTO: KATIE SMALE**



## ***CAST BIOGRAPHIES***

### ***Alana Ramsey (Alice Barnham)***

Alana trained at RADA. Theatre credits include: A Christmas Carol (The Bridge), Macbeth (National Theatre), The Importance of Being Earnest (The Vaudeville Theatre), Young Marx (The Bridge Theatre), The Glass Menagerie (Duke of York London), A Bright Room Called Day (Southwark Playhouse) for which she was nominated for a Best Actress Off-West-End-Stage Award; Unearthed (UK Tour).

Television credits include: House of The Dragon (HBO), The Crown (NETFLIX/HBO), Blitz (BBC one), Bulletproof (SKY), Doctors (BBC one), Silk and Doc Martin (ITV) Film credits include: Between the Lights, Common People and Belle (20th Century Fox). Radio credits include: The Machine Stops, Starship Titanic, Body Tourists, We're Backing Britain, Number 10, Two Minutes Hate, The Mysterious Death of Jane Austin, The Russian Gambler, Best Q, Heading to Paradise, Burn Baby Burn (all for BBC Radio) and Sheltered (Audible).

### ***Oliviero Papi (William Rawley)***

Oliviero is an Italian born, Australian artist, performer and pedagog. He trained at the Victorian College of the Arts in Melbourne, Australia and worked professionally in theatre for a number of years, notably with Bell Shakespeare Company and the Sydney Theatre Company, until he transferred to Europe in 2004. Oliviero is a co-founder of OBRA and the Au Brana centre in France. With OBRA Oliviero is the co-creator of artistic projects, a dramaturg, performer, workshop leader and teacher. He manages the facilities of the Au Brana centre and hosts artists in residence.

Oliviero has worked with many different companies in Europe, most notably Awake Projects (SW), Teatropersona (IT) and Teatr Piesn Kozla (PL). Oliviero regularly collaborates with the filmmakers at VIDEOfeet (UK) and is part of the artistic team of Ex-Situ Collective, a collaboration between OBRA and VIDEOfeet.

**PHOTO: BENJAMIN ALUWIHARE**

# **CREATIVE BIOGRAPHIES**

## **Matt Smith**

Matt Smith is a writer/director originally from Watford, UK. He started making experimental short films during his time at Dartington College of Arts, which showed in competition at many BAFTA recognised festivals. He then spent years working as a promo filmmaker, video designer and artist-filmmaker. His artist films have been shown around the world with support from the Arts Council of England, The Arts Council of Wales and Drac Occitanie - Ministère de la Culture, (France), among others. His work often explores unsettling realities and imagined histories, blurring the line between what is real and what is fantasy. He is now focused on making narrative films.

## **Rhian Smith**

Rhian is an emerging narrative producer and works closely with writer/director Matt Smith, with whom she co-founded micro-studio / production company VIDEOfeet. After producing several digital media projects supported by Arts Council England exploring the use of film and live performance she produced the UK tour of the official adaptation of Ted Hughes Gaudete with OBRA Theatre Company (FR) then co-produced a series of artist films in the Gers region of France. Rhian has also worked as Brand Manager for Trestle Theatre Company since 2009 and in partnership with Matt currently developing their first feature.

**PHOTO: CREW, ALLER PARK, DARTINGTON**





### ***Joby Newson***

Joby is a filmmaker, drone pilot and camera operator from Mid Wales who has worked for big brands, arts projects and broadcast productions across the globe.

Working across a range of industries, Joby has created educational content for the BBC, TV adverts for holiday brands, social media content for some of the world's biggest football clubs and has been a documentarian on everything from big budget film sets to national arts projects and TV dramas. Since 2019 Joby has been the aerial and motion photography lead for the Indonesian TV documentary series *Dream Chasers: Garuda Select* on MolaTV, and was a camera operator for the FX series *Welcome to Wrexham*.

### ***Simon Clode***

Simon is an Artist / Filmmaker / Video Designer and his work combines a number of disciplines. He is interested in ethnographic, environmental and political commentary, and that globally. His films have been shown in competitions for BAFTA, such as the Aesthetica Short Film Festival. He was a video designer on a number of national and international theatre and dance projects. The Arts Council of Wales supports his artist films, with its latest film installation to be seen at the Palestine Contemporary Arts Festival, 'Qalandiya International'. He is currently one of the directors selected for the BFI Network X program | BAFTA CREW 2021, and is also sponsored by BFI Horizons.

### ***Richard Reed***

Richard is a highly experienced VFX professional with 18 years of expertise in the industry. He has worked on numerous blockbuster movies such as 'Pan's Labyrinth', 'The Dark Knight' series, 'Inception', and 'Harry Potter and the Half-Blood Prince'. Richard's exceptional work on 'The Man Who Fell to Earth' earned him an Emmy nomination for Outstanding Special Visual Effects in a Single Episode. He has also served as HOD on projects such as 'Final Portrait', 'Striking Vipers' (S5 E1) of 'Black Mirror', and Sky's 'Riviera Season 2'. As a HOD at DNEG he contributed to the creation of images for the Academy Award-winning movie 'Inception'. The team also received 8 BAFTA nominations for their contributions to the 'Harry Potter' franchise, winning 3, and won an Emmy and VES award for their work on other projects.

### **Nick Davies**

Nick is a highly experienced sound recordist, having worked across cinema, TV productions for major broadcasters, and commercials for some of the biggest household names.

Nick's passion for sound led him to expand into dubbing mixing and sound design. He has extensive experience mixing and sound designing for TV, film and commercials. In 2020 he founded Meteor, a 5.1 surround sound post-production studio based in Cardiff.

### **Alex Hyland**

Alex is an award-winning composer and dance music producer with a BSc (Hons) in Music Technology and releases dating back to 2004. Alex has an artistic partnership with Matt Smith spanning 20+ years, working on Arts Council funded mixed media projection/theatre project Thadows which resulted in performances at Trestle Arts Base and Rich Mix.

He releases solo experimental music as 'EXTRASUPER' and dance music as 'Des O'Carger' as well as collaborative work with Matt Smith as 'Arthur Winkler NOW!' In addition to his music work, Alex designs & hand-crafts headphones for the audiophile and professional market as Hyland Headphones.

### **Keir Vine**

Keir Vine is a Composer and Sound Designer who writes across multiple mediums and performs worldwide with Mercury Music Prize-nominated group Portico Quartet.

Recent scores include the feature-length documentary 'More Earth Will Fall' by Sam Liebmann and Lee McKarkiel alongside the award-winning Short 'Hands' by Zara Burdett. Keir's recent installation work includes composing the soundscape and designing the spatial array for 'Ouroboros' at Click festival in Denmark, and the 5G networked performance 'Epiphany' in the Guildhall, alongside participatory installation 'Now Is The Time To Say Nothing' at the Young Vic. Within theatre Keir has worked on many shows including at the Bristol Old Vic, Young Vic, Battersea Arts Centre, RADA, Kings College London and The Albany. Keir runs a recording and post-production studio, Studio 9 where he is based as a Producer, Composer and Sound Designer. His first Solo LP, 'Instance' is available on Trestle Records.

# ***PROCESS***

## **CINEMATOGRAPHY**

Matt had a very strong vision of how the cinematography would work. He has DP'd all of VIDEOfeet's films so far so understood the needs of the production.

His desire was for the cinematography to resemble the aesthetics of films like *Under the Skin*, *Ratcatcher*, and *The Witch* with the camera movements being made of wide static shots mixed with simple flowing dolly shots with minimal handheld work.

This allowed the more remarkable moments in the film - the artwork, the negative, and the building itself to stand out, a glowing colourful ember signifying the film's shift into science fiction horror.

***PHOTO: KATIE SMALE***

## LOCATIONS

The key to NEW ATLANTIS and probably the key to the success of the film was the abandoned spaces. After initially searching for these locations in the South East it quickly became clear that the access costs were hugely prohibitive and so the search was widened in order to find an alternative.

Rhian and Matt both have connections with Dartington Hall Estate as graduates from Dartington College of Arts and as such negotiated the use of an old school building on site which has been mainly derelict since the 1980s. Once this location was secured they started to look for the exterior location. After coming across some videos on YouTube they contacted Fastglobe LTD, the company currently managing the derelict milk processing plant in Totnes. This site was only a mile away from the production base and they were successful in securing the location for the exterior shots.

Under The Water Media provided the tank studio and the shoot was aided greatly by Simon and his team, allowing them to capture this essential aspect of the ending to great effect, with all studio work shot at Trestle Arts Base in St Albans.

## PRODUCTION DESIGN

The production design of the film was overseen and created by Matt and Rhian Smith along with the help of the Production Assistant and long-term collaborator James Christian.

Matt created the seven artworks featured in the film, inspired by and using elements of 19th-century French artist Gustave Doré which were then giclée printed and hand gilded before being framed.

Matt also designed the NEW ATLANTIS logo which features on many of the peripheral details of the set dressing.

**PHOTO: BENJAMIN ALUWIHARE**

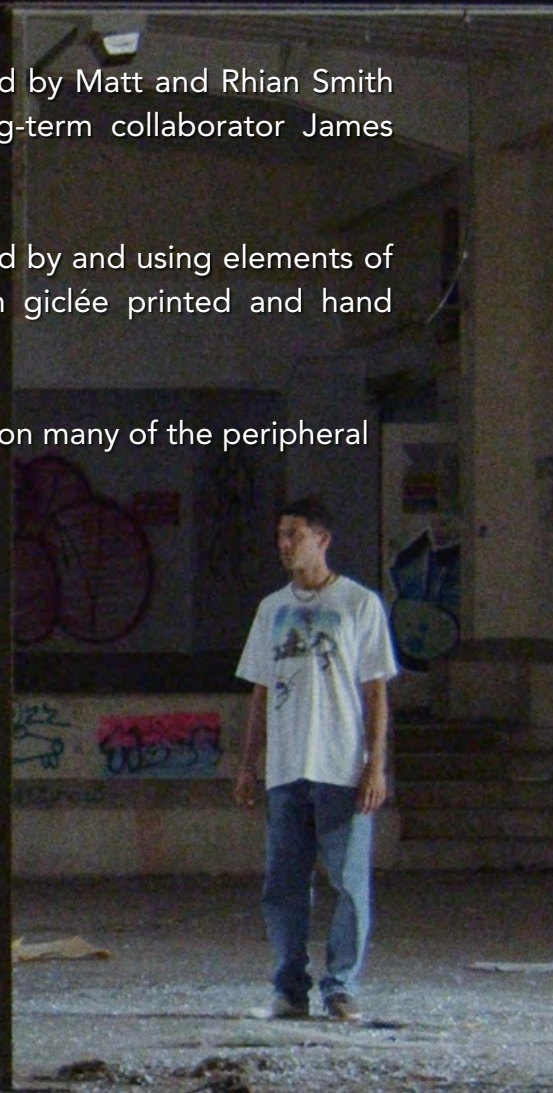

## PRODUCTION DESIGN continued

Once created the logo was then added to the various documents created for the film. This process included identifying relevant works and adapting layouts and titling to fit with the film's narrative.

Rhian also undertook all costume design and implementation, as well as all other set design. Most of these were created using found objects and age related technology to bring into the space. The interior forest was created using live plants that were collected before the shoot and bolstered by the use of fresh cuttings provided by the Dartington Grounds team.

One of the most important aspects of our approach to design is working with what is in situ and Aller Park had a wealth of furniture and debris that contributed to the overall aesthetic of the film.



## SOUND

Matt (who has always sound-designed and co-scored VIDEOfeet's films) collaborated with sound designer Alex Hyland and composer Kier Vine. Matt and Alex have worked closely together since University producing sound worlds and scores for various films and it was important that this relationship continued.

Keir has collaborated with VIDEOfeet on several projects and brought his knowledge of music to good measure in producing the more musical elements in the film, such as the party music at the beginning and how that could be present in some way in the mesmerising soundscape at the end of the film.

The process heavily involved experimenting with recording on tape ribbon and then physically manipulating it.

Matt, Alex and Keir spent time making recordings of building materials, rubbing brick and concrete together, large wet stones, broken instruments, metal rails, fencing etc. in order to create source material for the score.



# ***FESTIVAL RECOGNITION***

## ***for recent Short Films***

### **BUGBEAR**

The British Short Film Awards (2021)

Finalist: Best Horror

Finalist: Best Supporting Actor

Nominee: Best British Director

Nominee: Best Sound Design

Nominee: Best Editing

On The Pulse Film Festival, Cinemagic (2022)

Selected

Cornwall Film Festival (2022)

Winner: Best Music

Winner: Best Cinematography

ALTER & DUST (2023)

Selected

MINUTE SHORTS (2023)

Selected

### **ISOSTASY**

Premiered on BBC 2 Cymru on Thursday 5th August 2021

The British Short Film Awards (2021)

Finalist: Best Welsh Short

Finalist: Best Score

### **L'HISTOIRE PEUT MOURIR SUR UN BALCON À FLEURS**

London Short Film Festival (2019)

Selected



## ***TECHNICAL INFORMATION***

RUNTIME: 14.57 minutes

FORMAT: Digital

AGE RATING 12a/PG13

Aspect Ratio: 1:66:1

Language: English

Audio Format: 5.1

***PHOTO: KATIE SMALE***

THE NATIONAL  
LOTTERY®

NETWORK

# ***new atlantis***

## **ASSETS**

POSTER: <http://bit.ly/400tsbw>

PUBLICITY IMAGES: <https://bit.ly/3TjiD2n>

BEHIND THE SCENES IMAGES: <https://bit.ly/3ZO8f4X>

SUBTITLE TRACKS: <https://bit.ly/403n2sm>

AUDIO DESCRIPTION: <http://bit.ly/3Ftylwy>

For all photography please credit VIDEOfeet.com

## **CONTACT**

[Rhian@videofeet.com](mailto:Rhian@videofeet.com)

07814730074

[www.videofeet.com](http://www.videofeet.com)

[www.exsitucollective.org](http://www.exsitucollective.org)

Instagram: [@VIDEOfeet](https://www.instagram.com/VIDEOfeet)

Twitter: [@VIDEOfeet](https://twitter.com/VIDEOfeet)

Facebook: [@VIDEOfeet](https://www.facebook.com/VIDEOfeet)

*PHOTO: KATIE SMALE*



Supported by Film Hub South East as part of

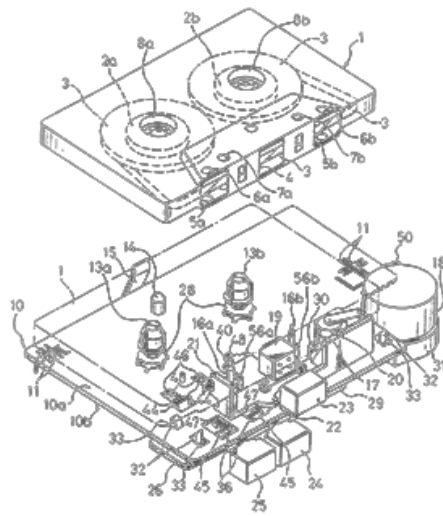

© MMXXIII VIDEOFEET.COM