

**I V A N K A  
A P O S T O L O V A B A S K A R**



**I N S E A R C H O F T H E L O S T  
D I R E C T O R  
U T O P I A N S E T D E S I G N S**



**M A C E D O N I A N C E N T E R I T I / P R O D U K C I J A**

**IVANKA APOSTOLOVA BASKAR**  
**“IN SEARCH OF THE LOST DIRECTOR”**  
**2009/2011**  
**UTOPIAN SET DESIGNS**  
**eBook**  
**(THEATER COMICS)**

**MACEDONIAN CENTER ITI/PRODUKCIJA**  
**SKOPJE 2020**



Република Северна Македонија  
Министерство за култура

**Title/Author:** *“IN SEARCH OF THE LOST DIRECTOR” - UTOPIAN SET DESIGNS (eBook) by Ivanka Apostolova Baskar*

**Project:** *Poor Little Rich Drama (The Rise and Fall of Drama, 2020)*

**Editions:** Theater and Performing Arts/Theater Comics

**Publisher:** Macedonian Center ITI/PRODUKCIJA

**URL.** <https://www.iti-worldwide.org/macedonia.html>

**Facebook.**

<https://www.facebook.com/MacedonianCenterofInternationalTheaterInstitute>

**YouTube.** [https://www.youtube.com/channel/UCdiN20fUtY067-\\_TWkeJMbQ](https://www.youtube.com/channel/UCdiN20fUtY067-_TWkeJMbQ)

**E-mail.** [macedoniancenterofiti@gmail.com](mailto:macedoniancenterofiti@gmail.com)

**Supporters:** Ministry of Culture R.N. Macedonia (2020); Ivanka Apostolova Baskar (2009/2020)

**Author:** Ivanka Apostolova Baskar (Visual Dramaturg; Comic Artist)

**Editor/Designer:** Ivanka Apostolova Baskar (Digital Curator)

**Introductory Text:** Maja Chankulovska-Mihajlovska (Curator; Art Historian)

**Language Editing:** Macedonian Center ITI/PRODUKCIJA

**Authors Rights:** The authors rights of this eBook belongs to Ms. Ivanka Apostolova Baskar (artist as digital curator)

**Copies:** 500

Skopje 2020

CIP - Каталогизација во публикација

Национална и универзитетска библиотека "Св. Климент Охридски", Скопје

741.9:792.021Апостолова,Б.И."2009/2011"(0.034.44)

APOSTOLOVA Baskar, Ivanka

In search of lost director [Електронски извор] : 2009/2011 : utopian  
set designs : theater comics / Ivanka Apostolova Baskar. - Skopje :  
Makedonski centar ITI - Produkcija, 2020. - 1 оптички диск ЦД-РОМ ; 12  
см. - (Edition Theater and performing arts/Theater Comics)

Текст во ПДФ формат, содржи [59] стр., илустр. - Poor Little Rich Drama  
(The Rise and Fall of Drama, 2020)

ISBN 978-608-4912-02-6

а) Апостолова Баскар, Иванка, 19??- -- Сценографски скици -- Театар --  
2009-2011 -- ЦД-а

COBISS.MK-ID 52519941

**Content:**

- **Theater Comics:** Towards "In Search of the Lost Director" by Ivanka Apostolova Baskar  
by Maja Chankulovska-Mihajlovska (Curator; Art Historian)

- **Theater Comics: Gallery**

- **Theater Comics: Internet Sources**

## **Maja Chankulovska-Mihajlovska:**

### **Towards "In Search of the Lost Director" by Ivanka Apostolova Baskar**

The exhibition of digital set designs "In Search of the Lost Director" by Ivanka Apostolova Baskar is a small retrospective of digital sketches made during more than a decade. In addition, it is inevitable to mention the fact that some of them are already exhibited in gallery format in 2009 (National Theater Museum, Ljubljana, Slovenia) and 2011 (Cinematheque of Macedonia, Skopje).

Ivanka Apostolova's impressive experience in the field of comics (deconstructed comics, collage comic, illustration, comic jewelry, etc.) and theater (set design, costume design, directing, production ...), always provokes the author towards new research experiments and adventures, resulting in works that push the boundaries of the visual and performing arts through multilayered intermediality and intertextuality.

From a formal visual point of view, the utopian set designs that are part of a long cycle called "In Search of the Lost Director", are dramatic abstract narratives about the positioning of man in an imaginary abstract minimalist set design, more precisely the digital space composed of combinations of geometric shapes and different textures. Geometry, as the basis of the narrative of the stage arrangement, is not only present in the construction of the mise-en-scène, but also the anonymous human figure itself is built of geometric shapes, where the pose is always the same - counterpoint as dramatic shift in utopian abstract performance, whether the figure is alone or multiplied in space. The texture as a visual moment in this minimalist constructed space (minimalist according to the use of color and shape) is performed through "microscopic" magnification of various structures or details that grow into a separate space with emphasized symbolism of gray (existential) impersonality with rare color accents and "real" objects.

The human-space relation in the digital set designs "In Search of the Lost Director (utopian sketches and visual reflections for stage design)" is built on the limitless digital possibilities with collage references, over which the conceptual discourse on the limitless search of the man (the perfect "lost" director) in the digital utopian, but also in the real utopian world, is built.

**In Search of the Lost Director**

**UTOPIAN SET DESIGNS**

**(Theater Comics)**

**Sketch Up Digital Drawings**

**2009/2011**

**In Search of the Lost Director - UTOPIAN SET DESIGNS - Theater Comics**

**Gallery**

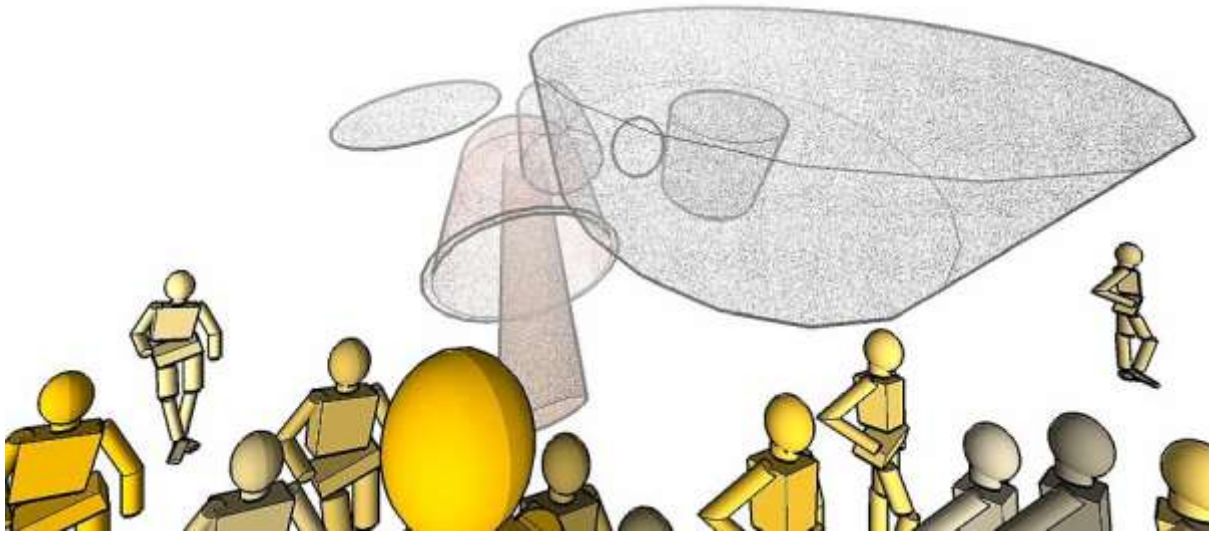

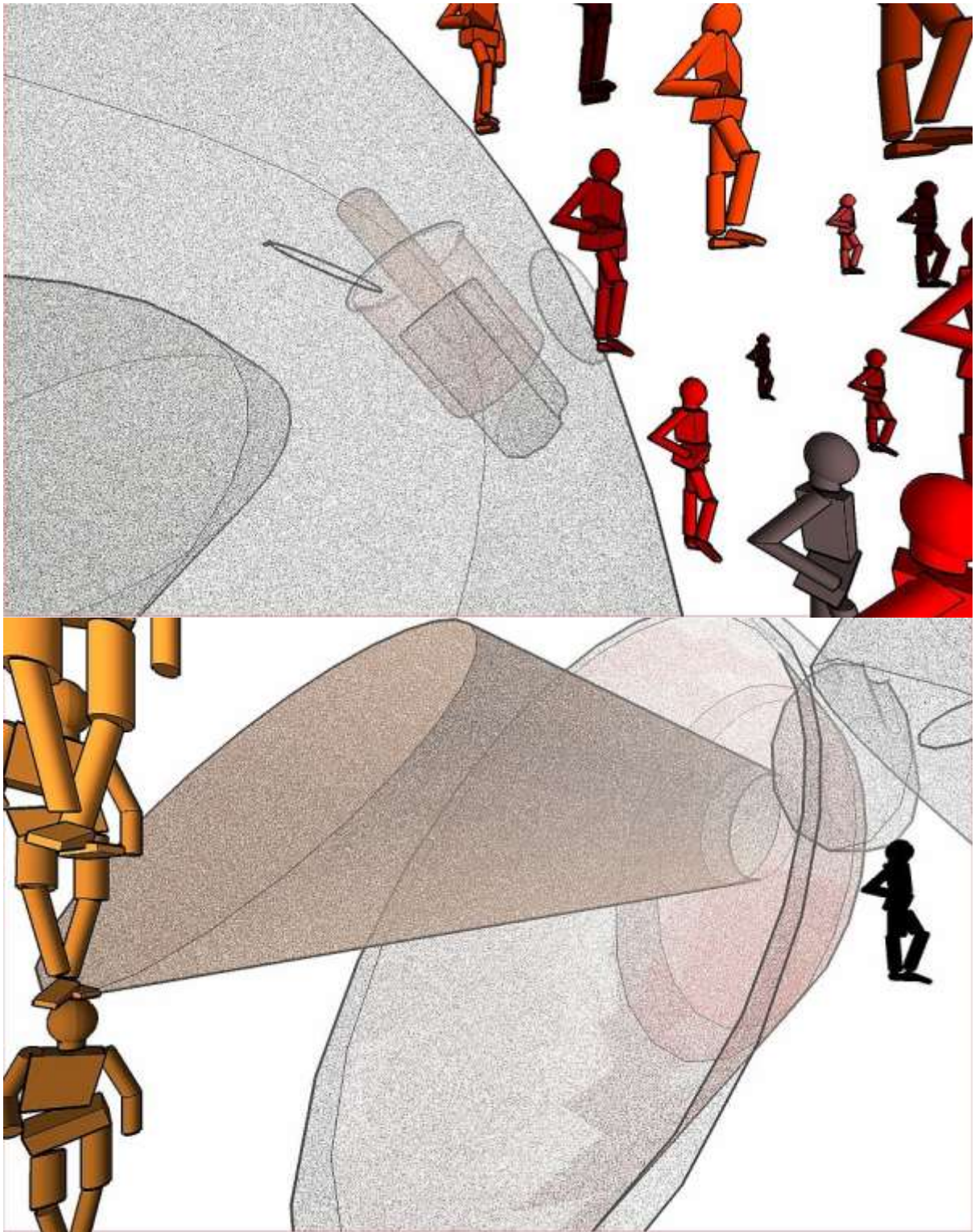

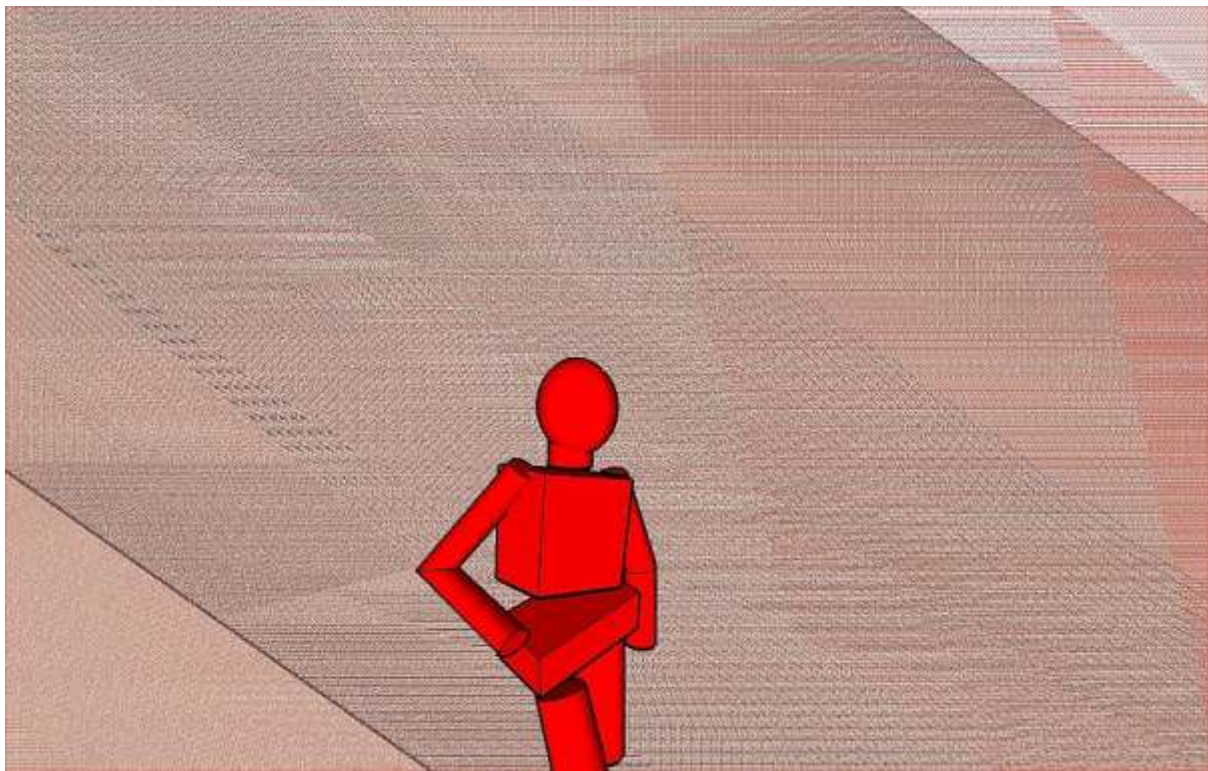
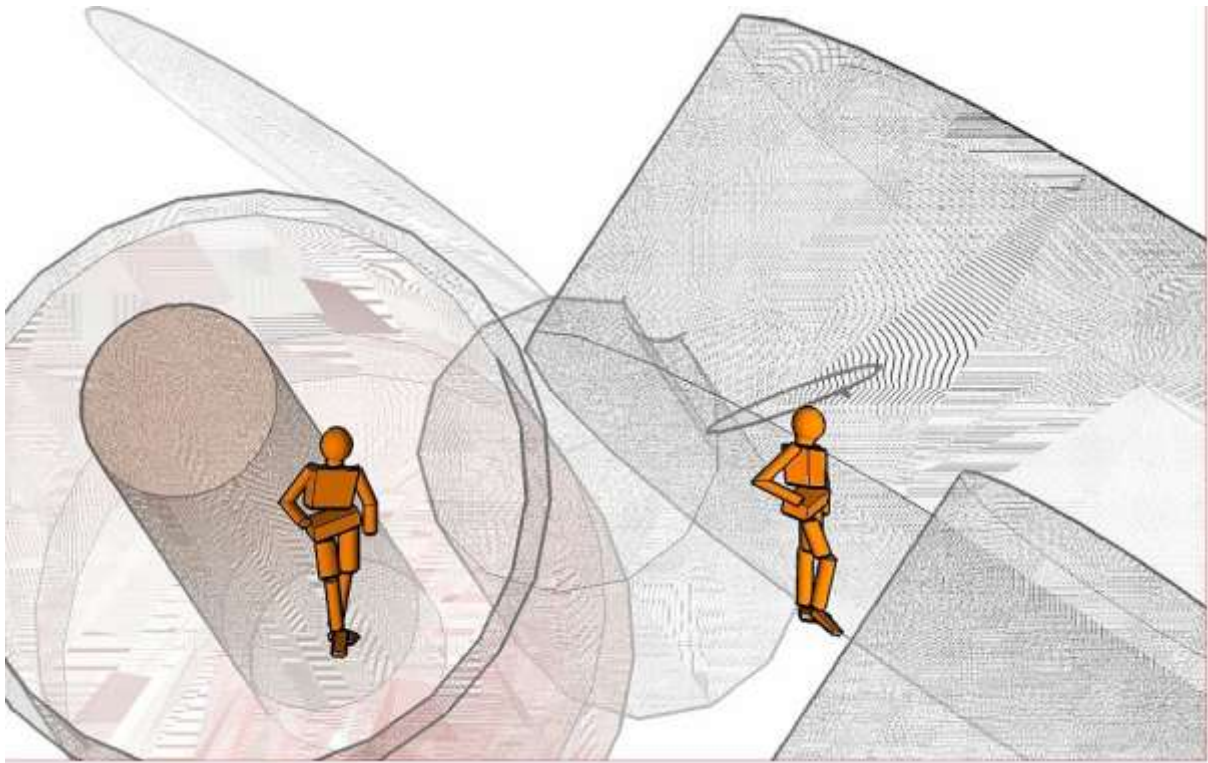

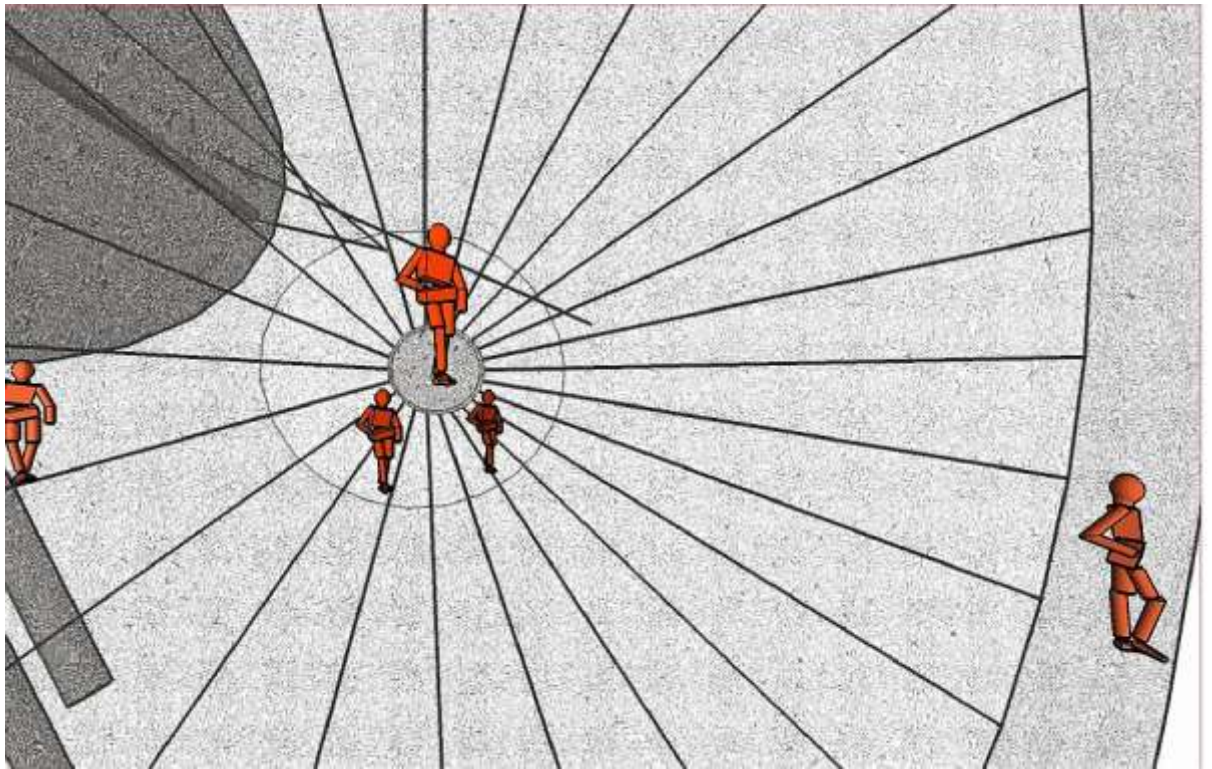
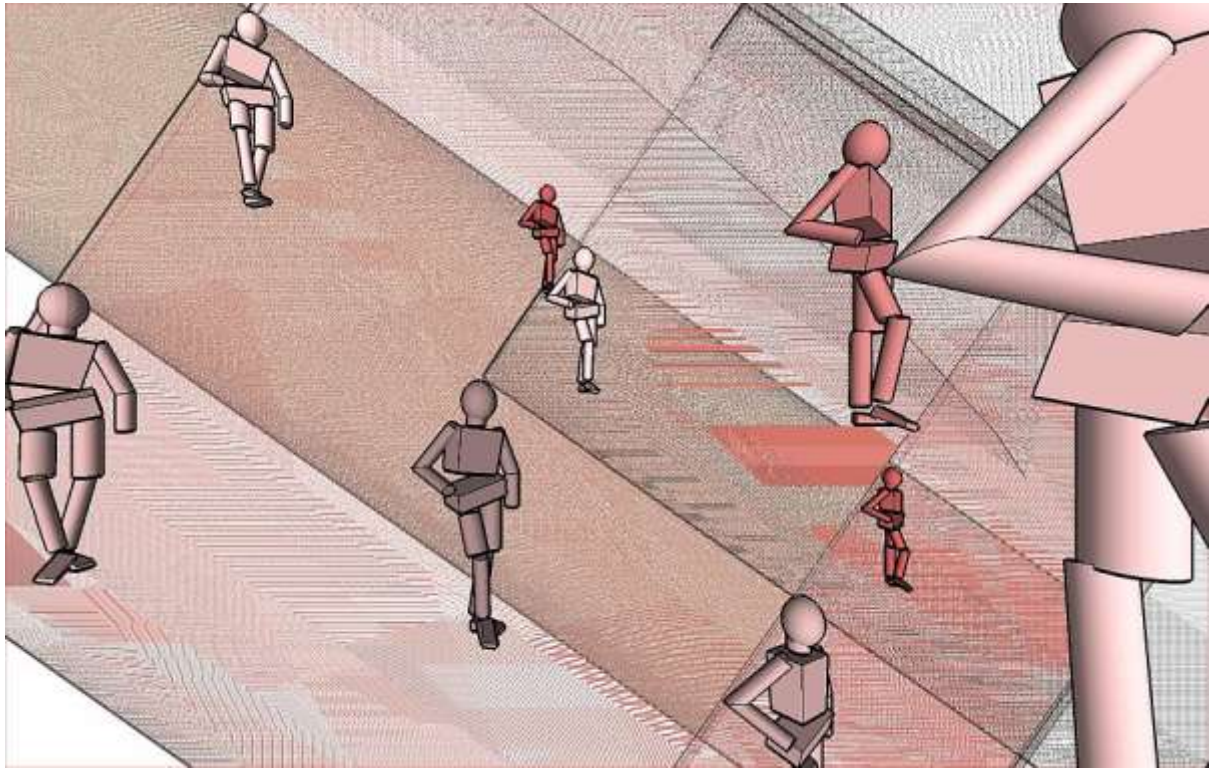

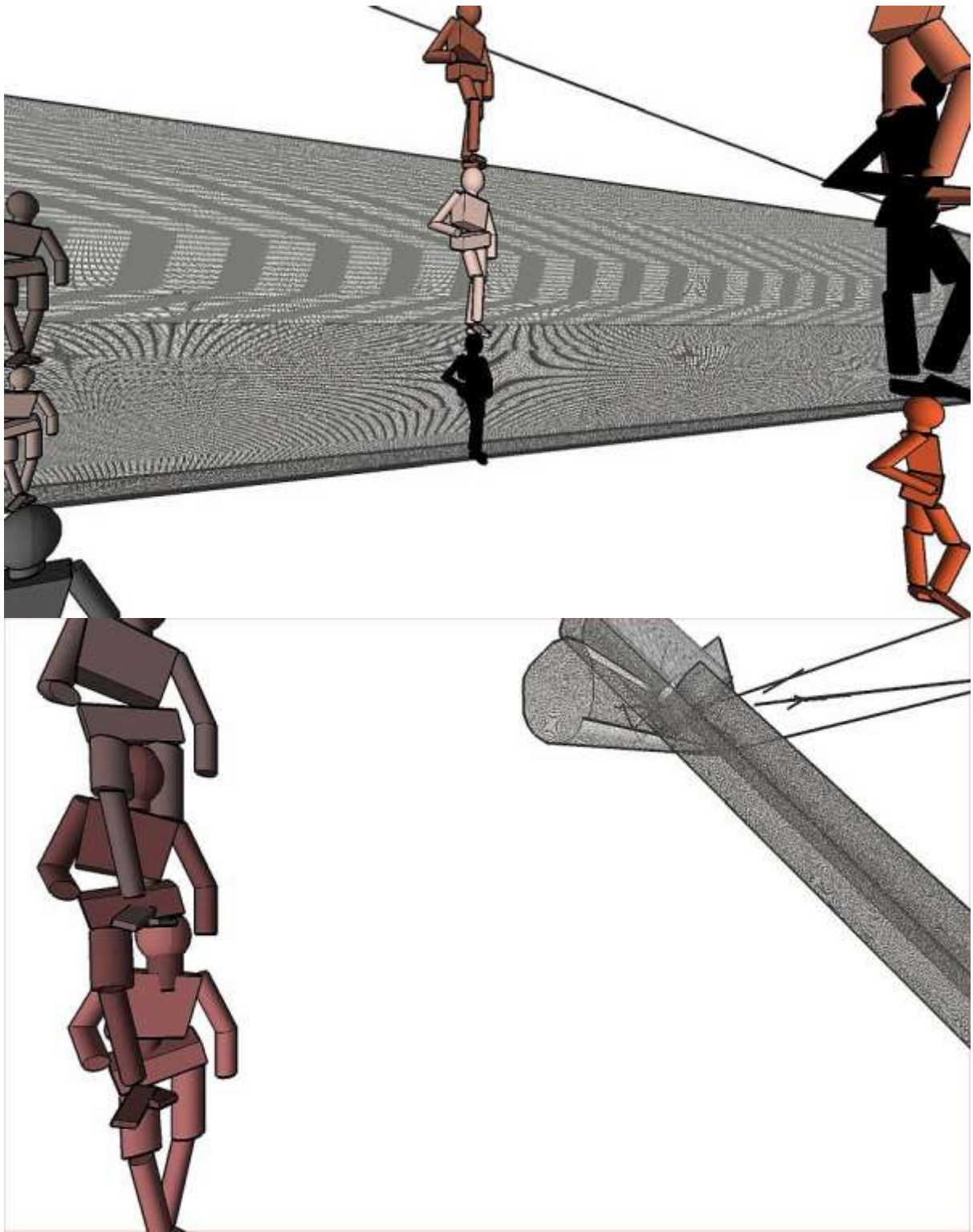

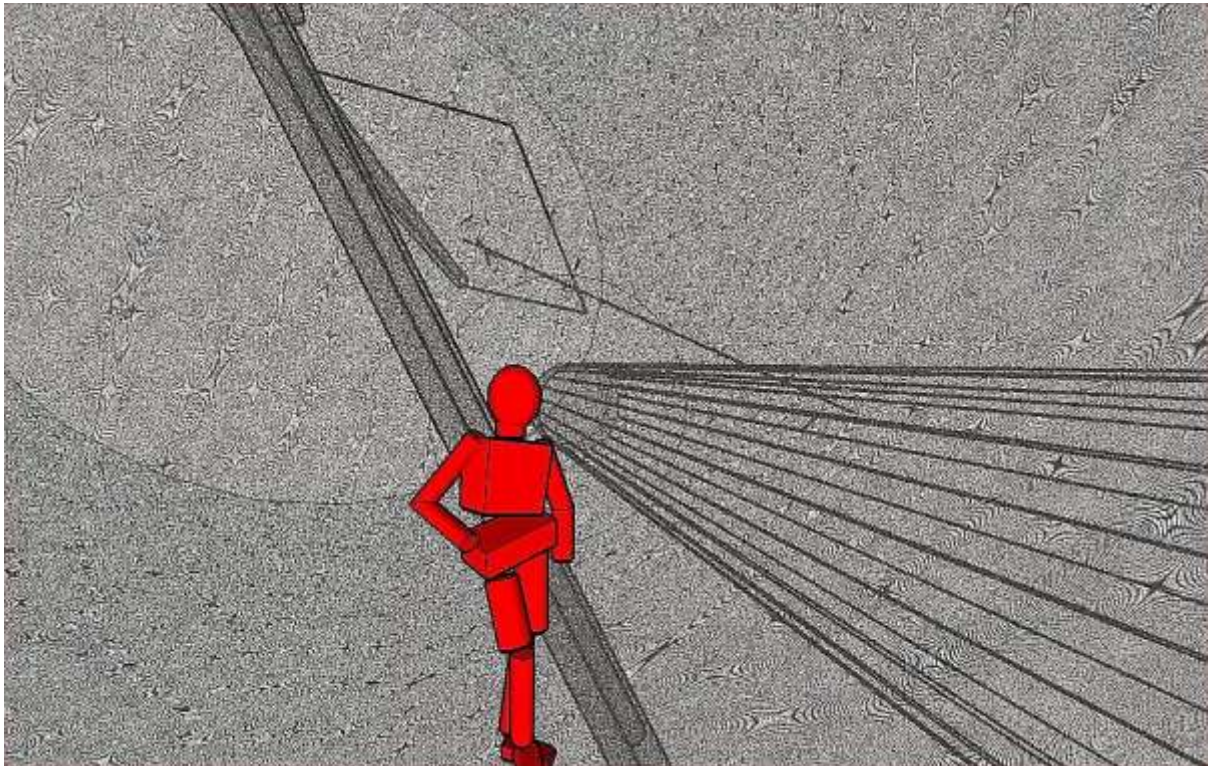
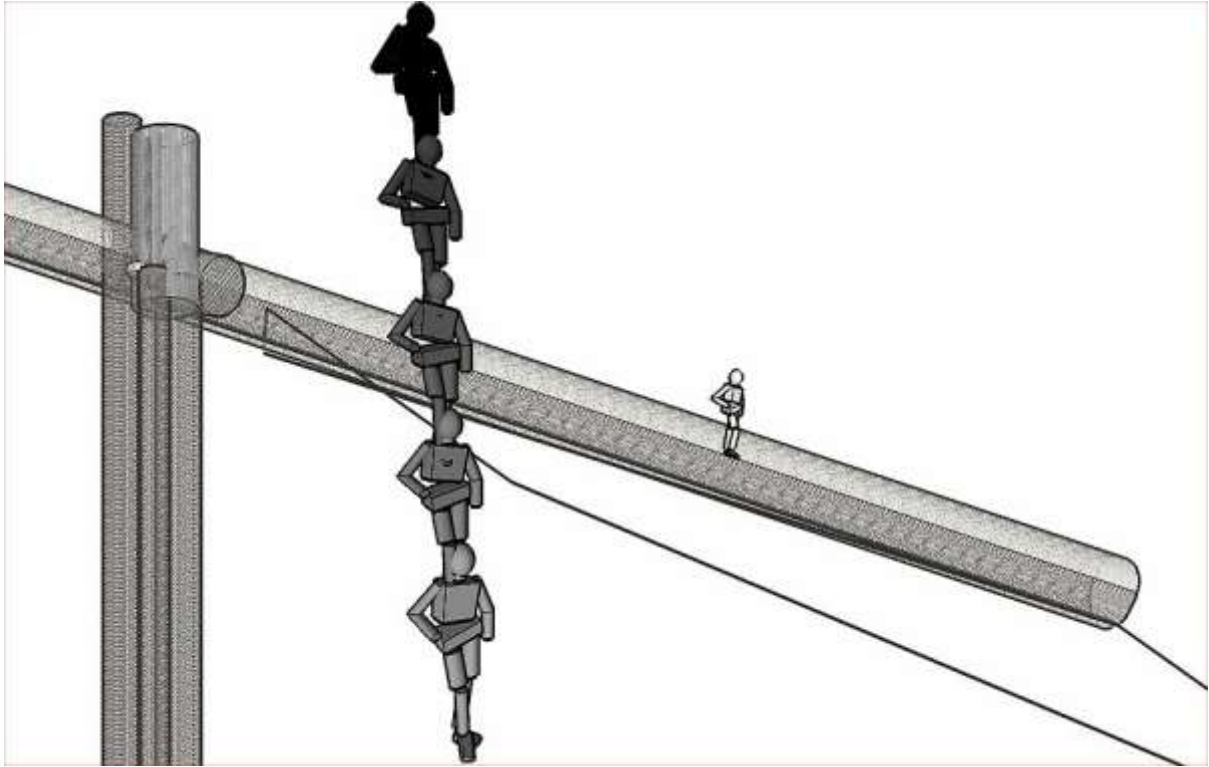

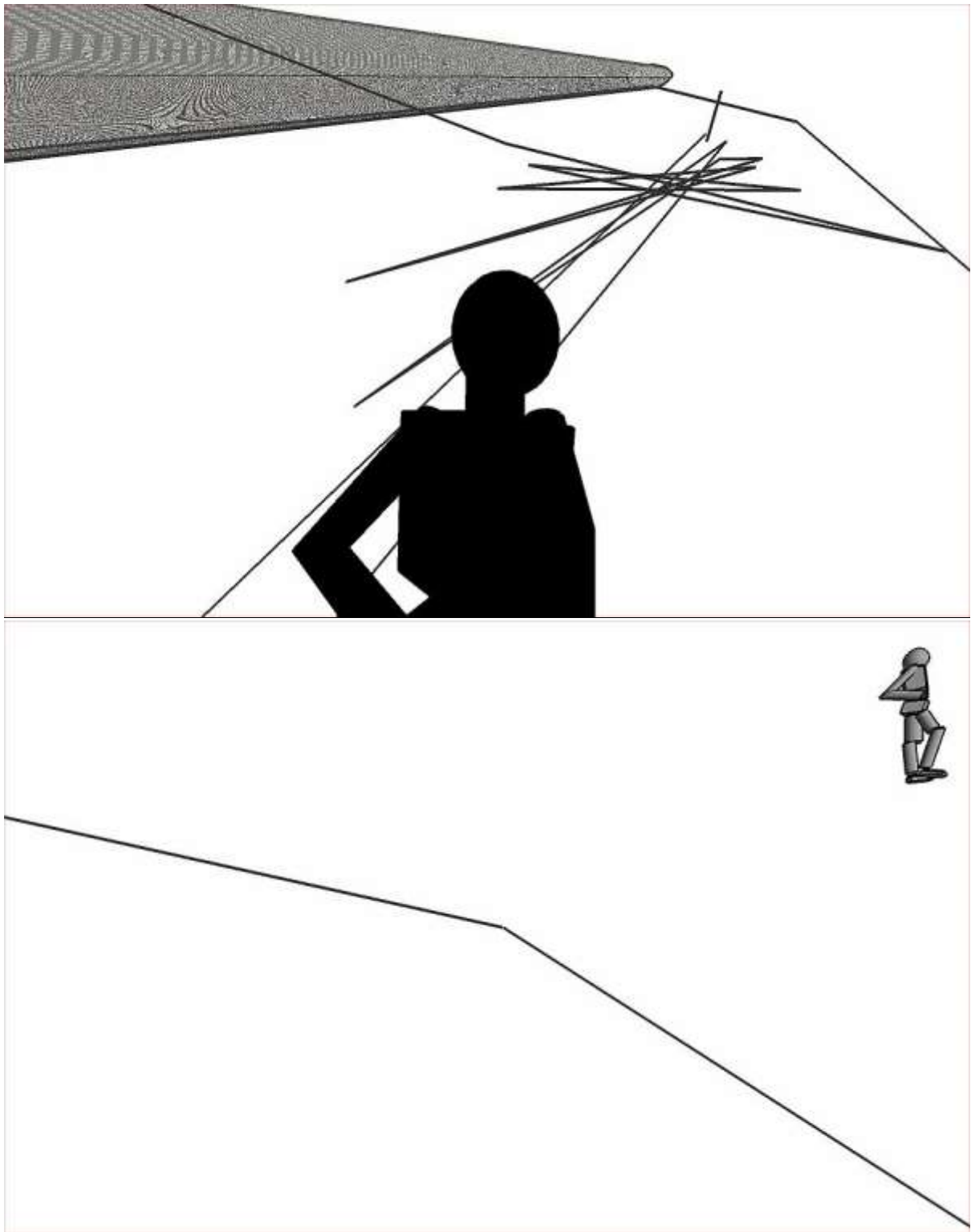

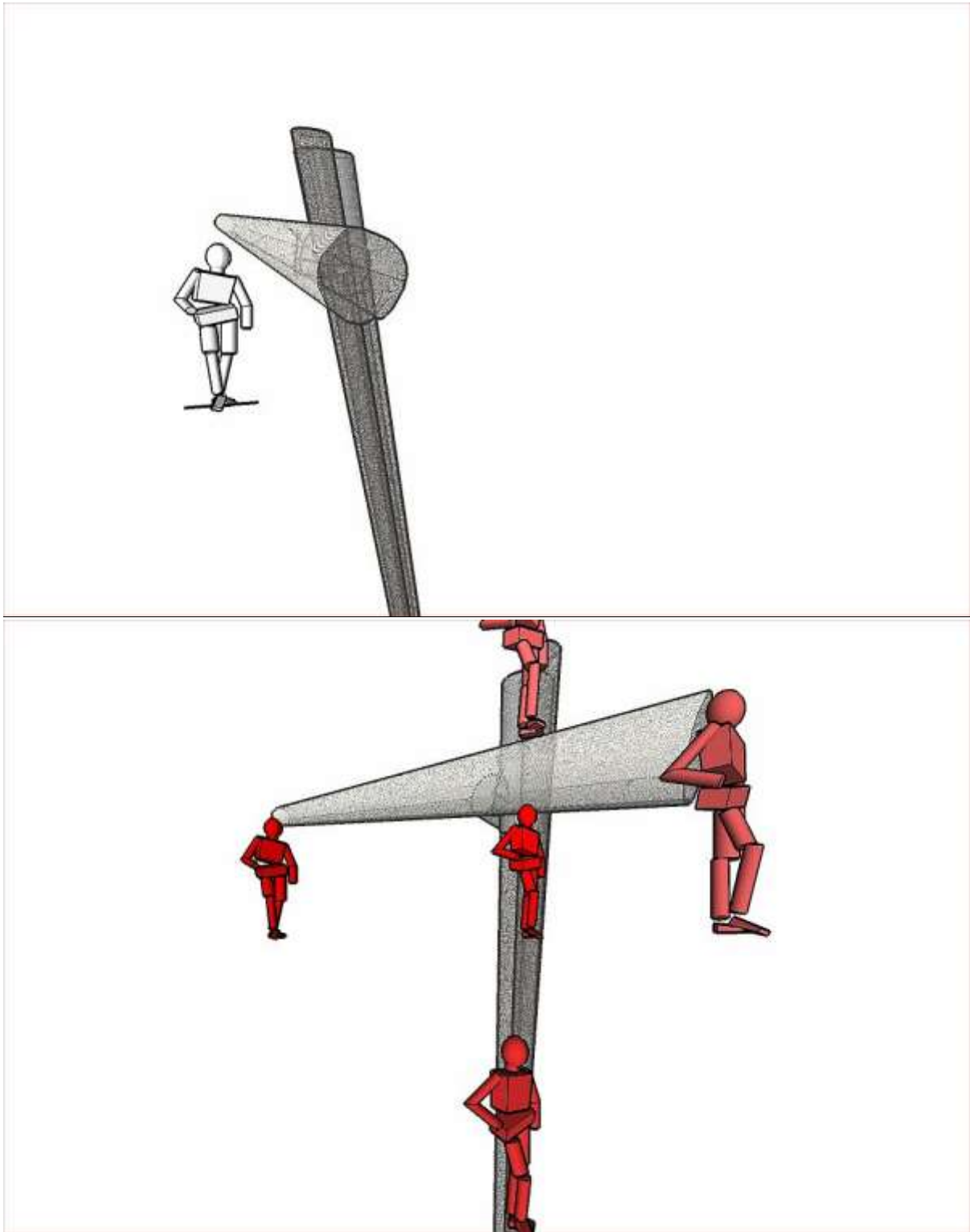

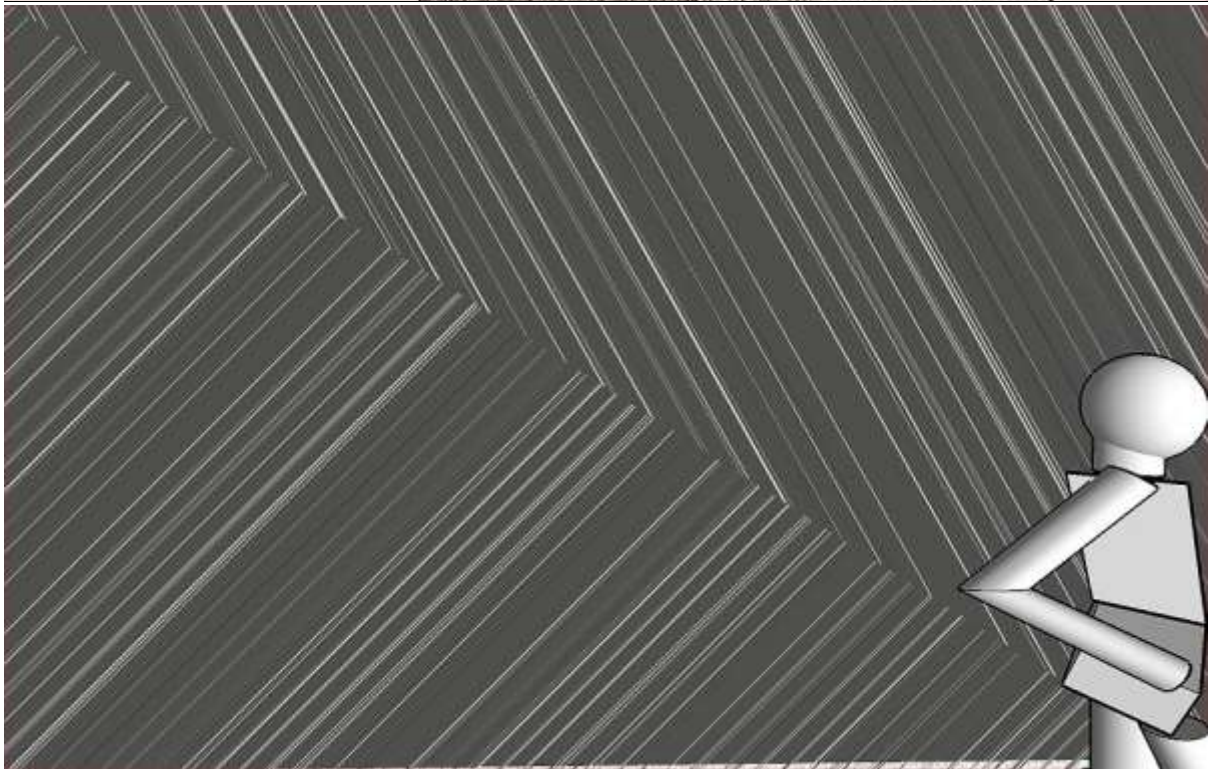
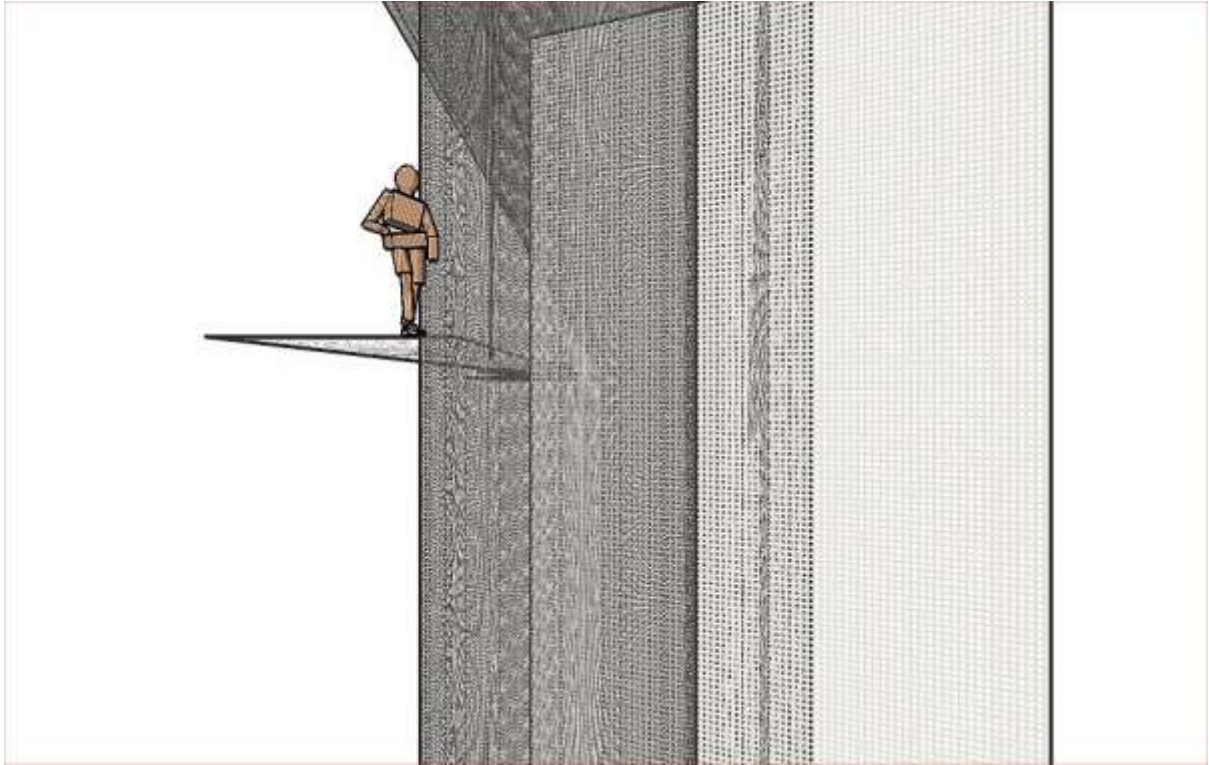

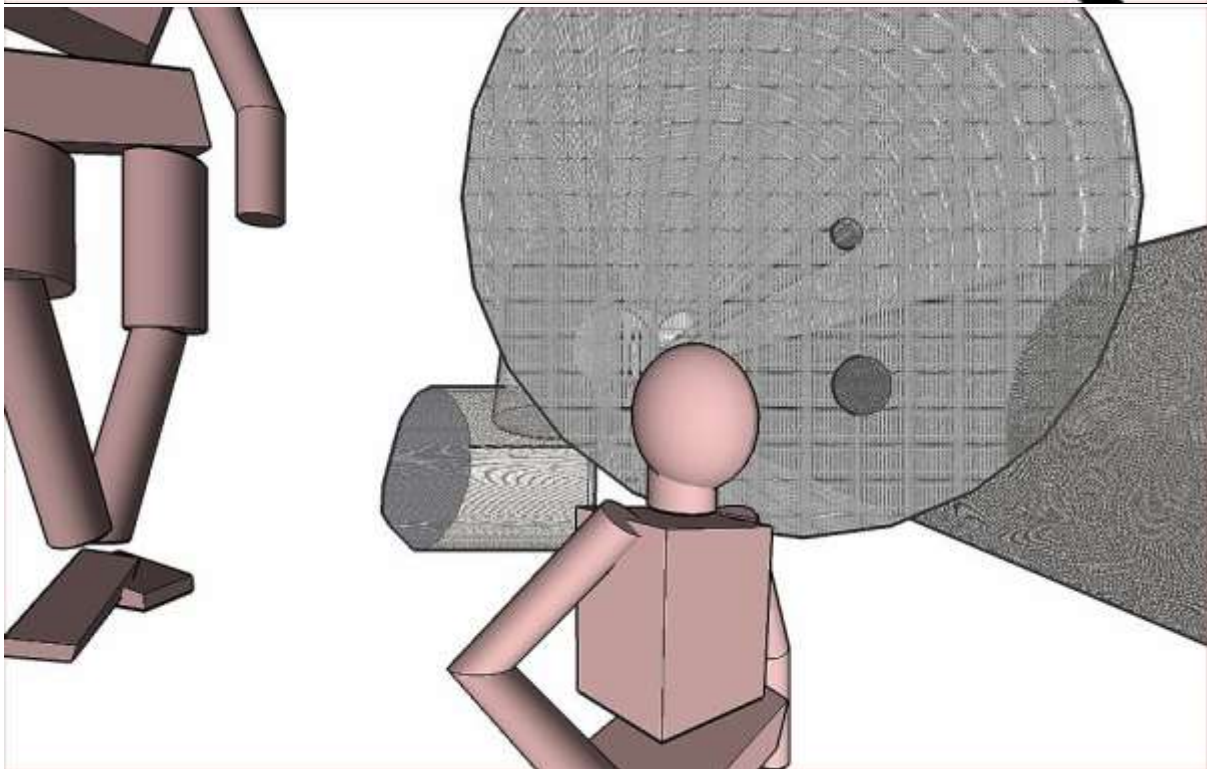
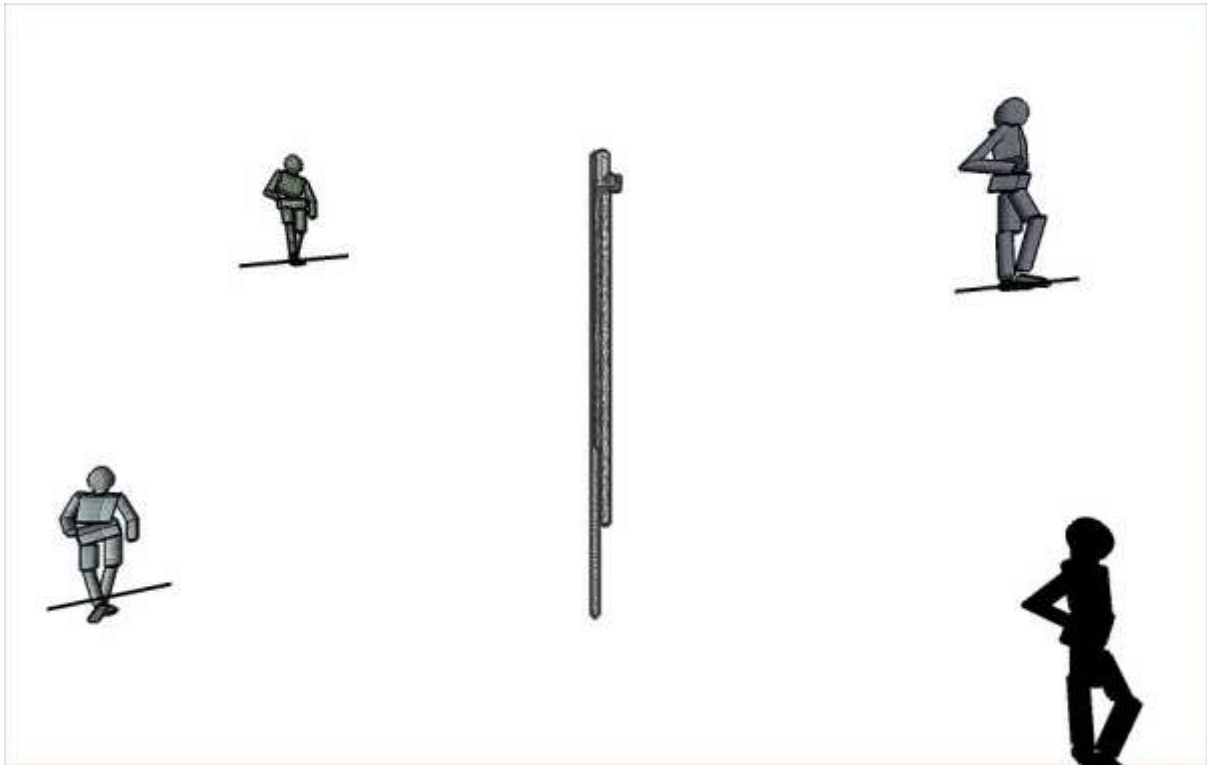

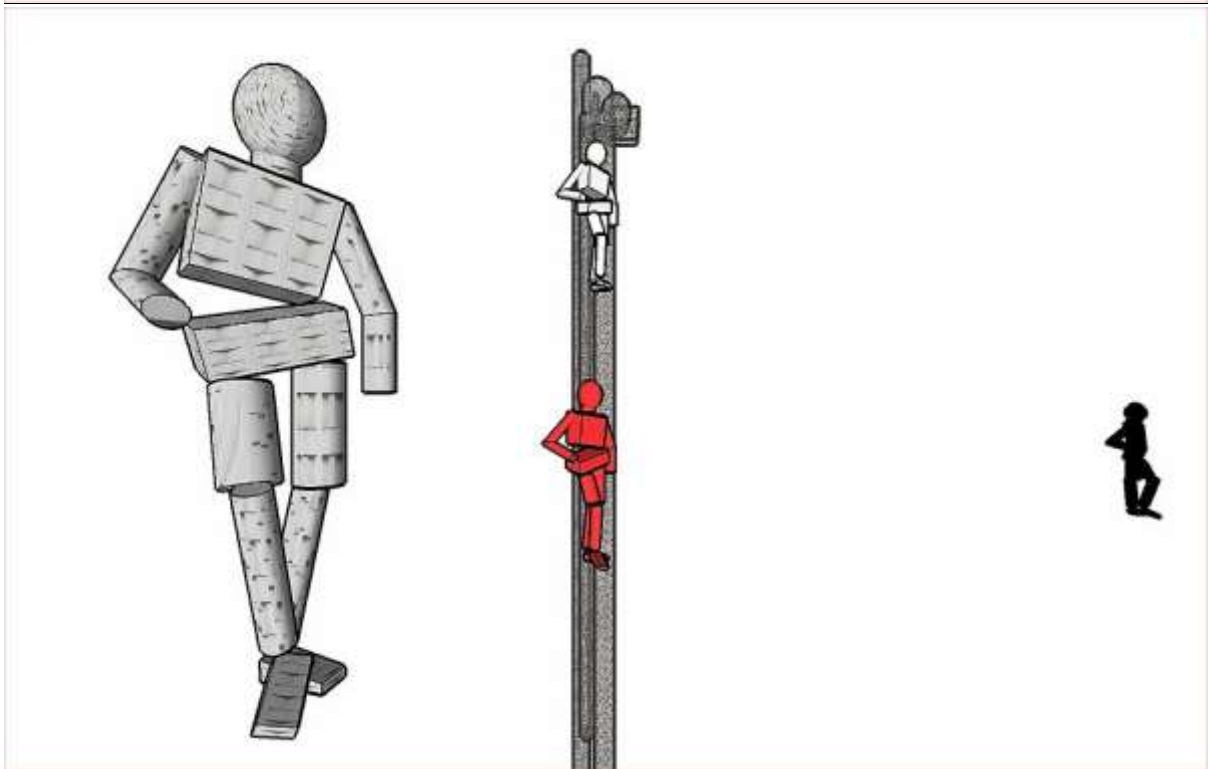
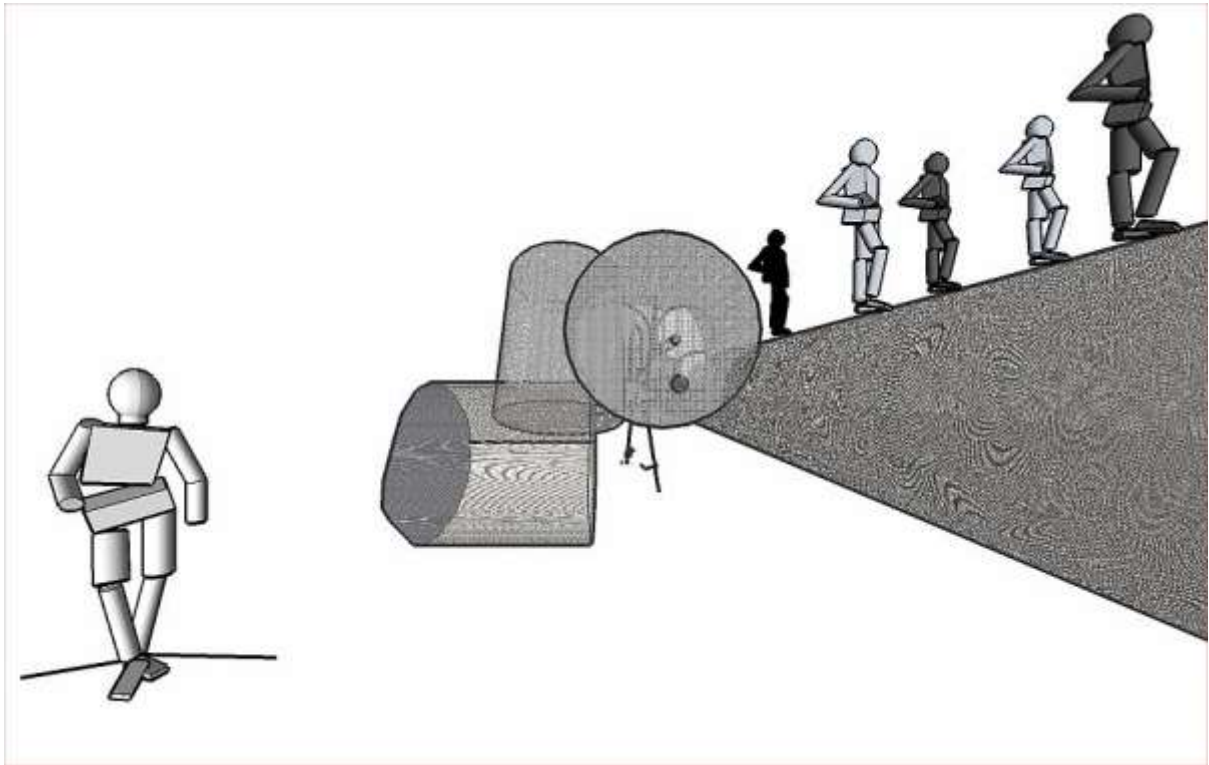

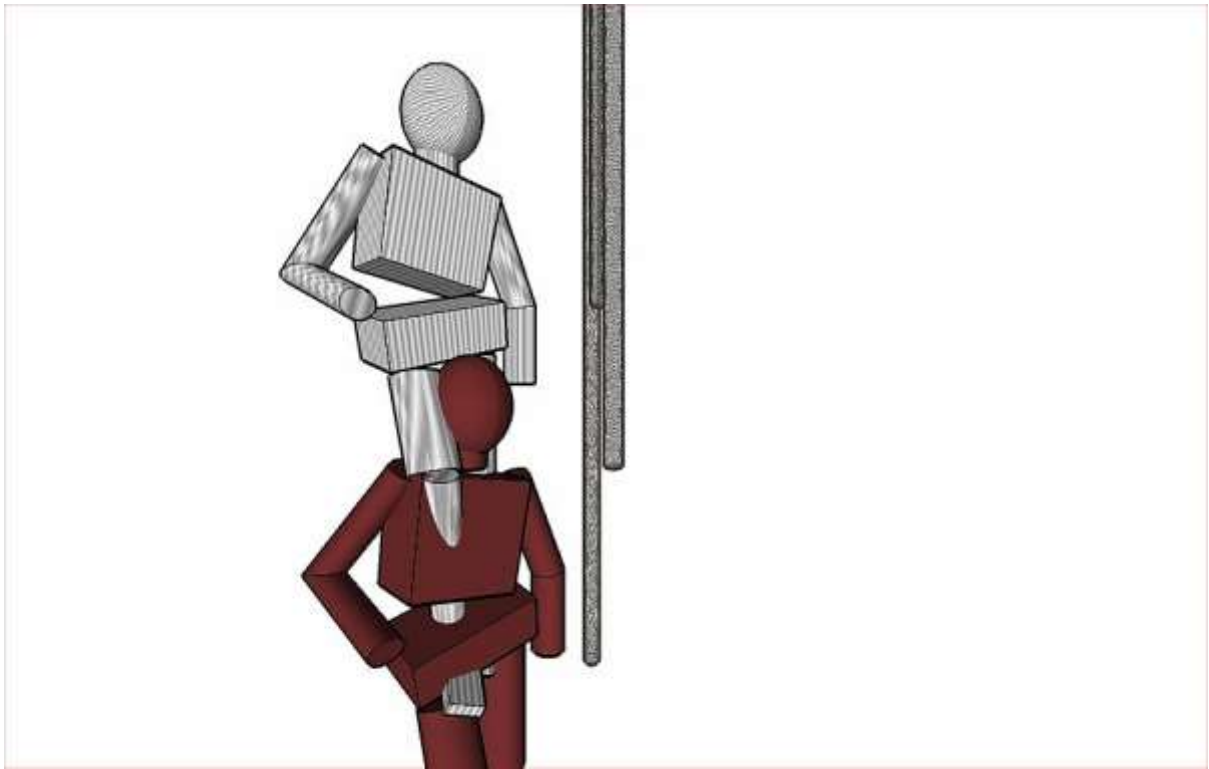
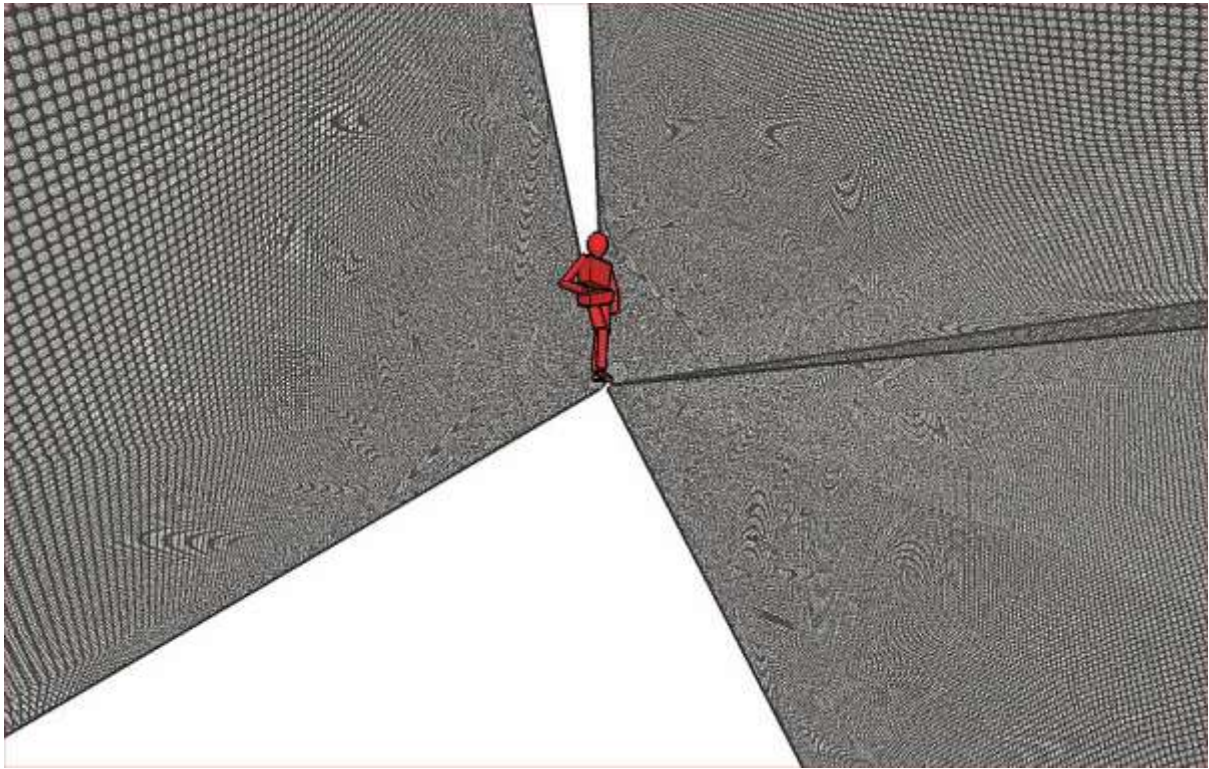

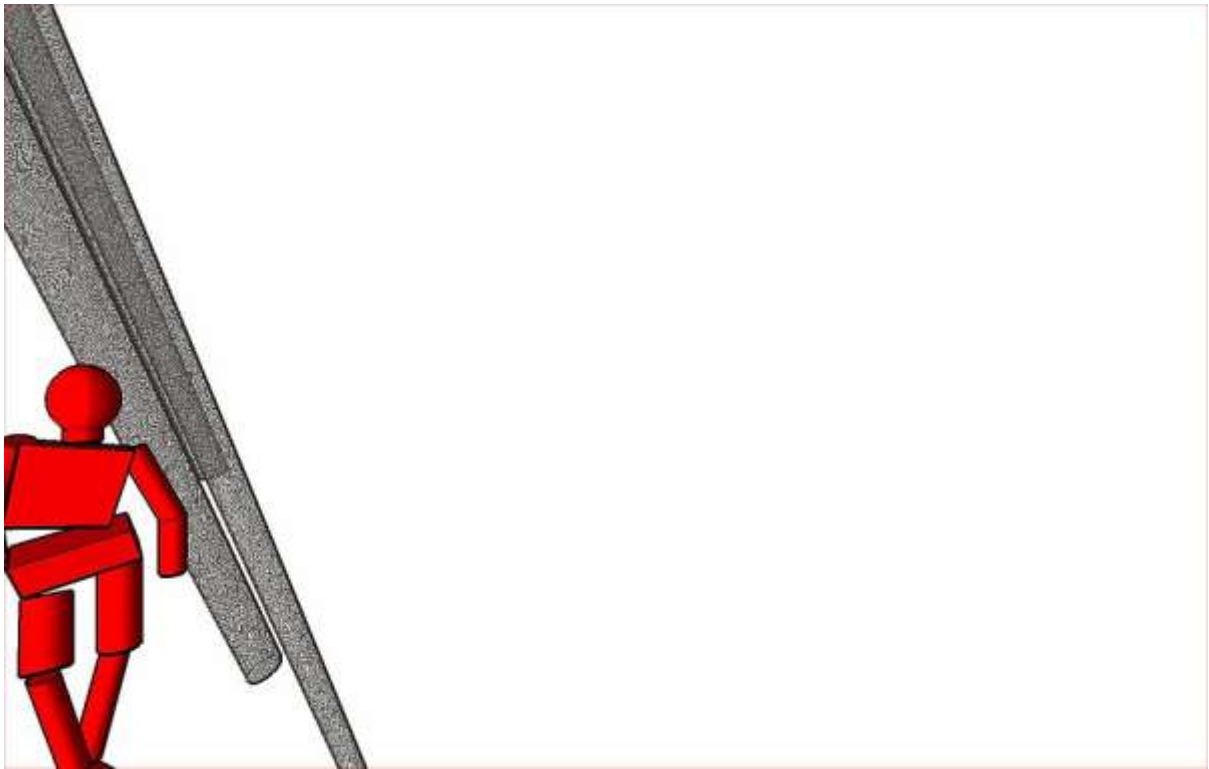
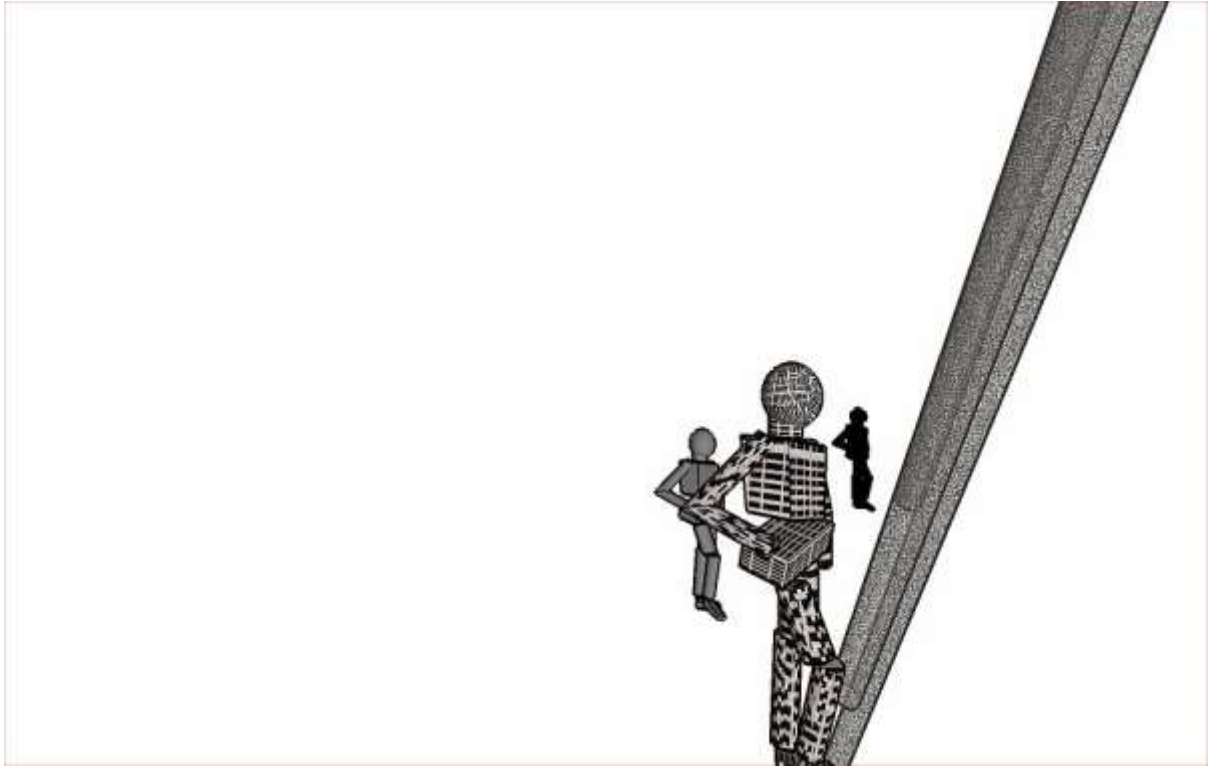

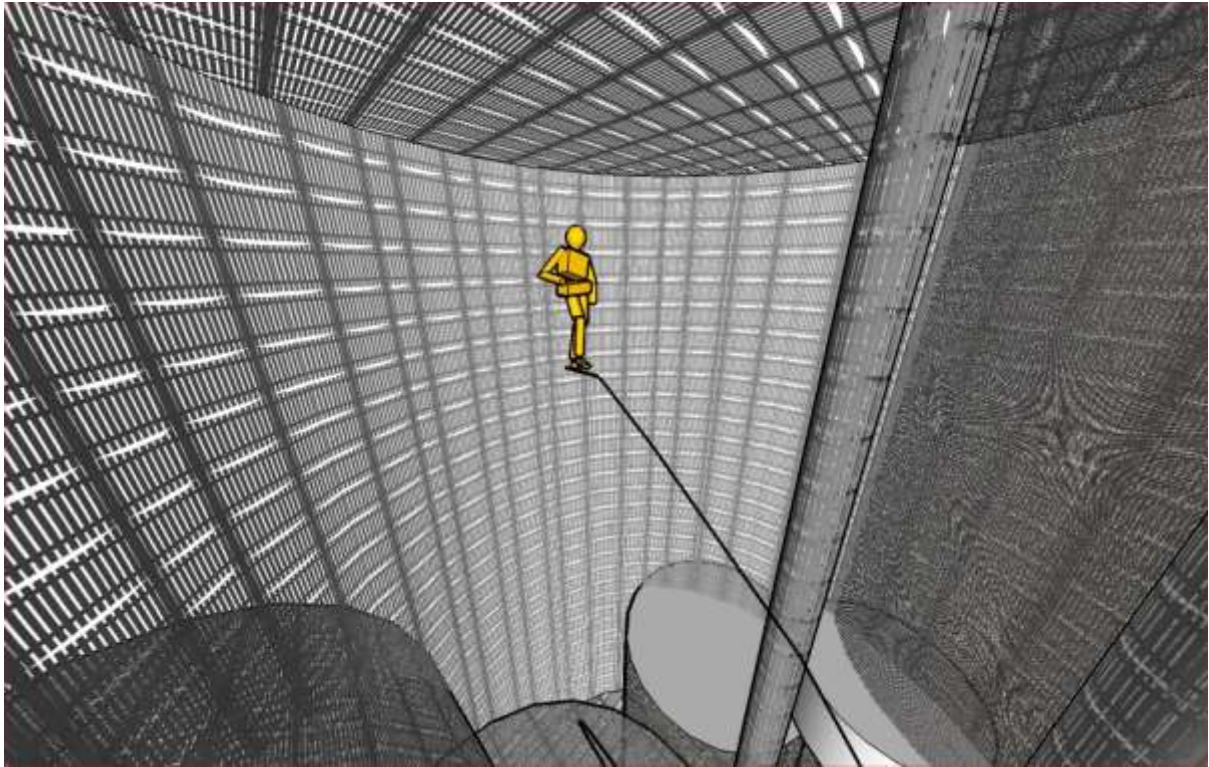
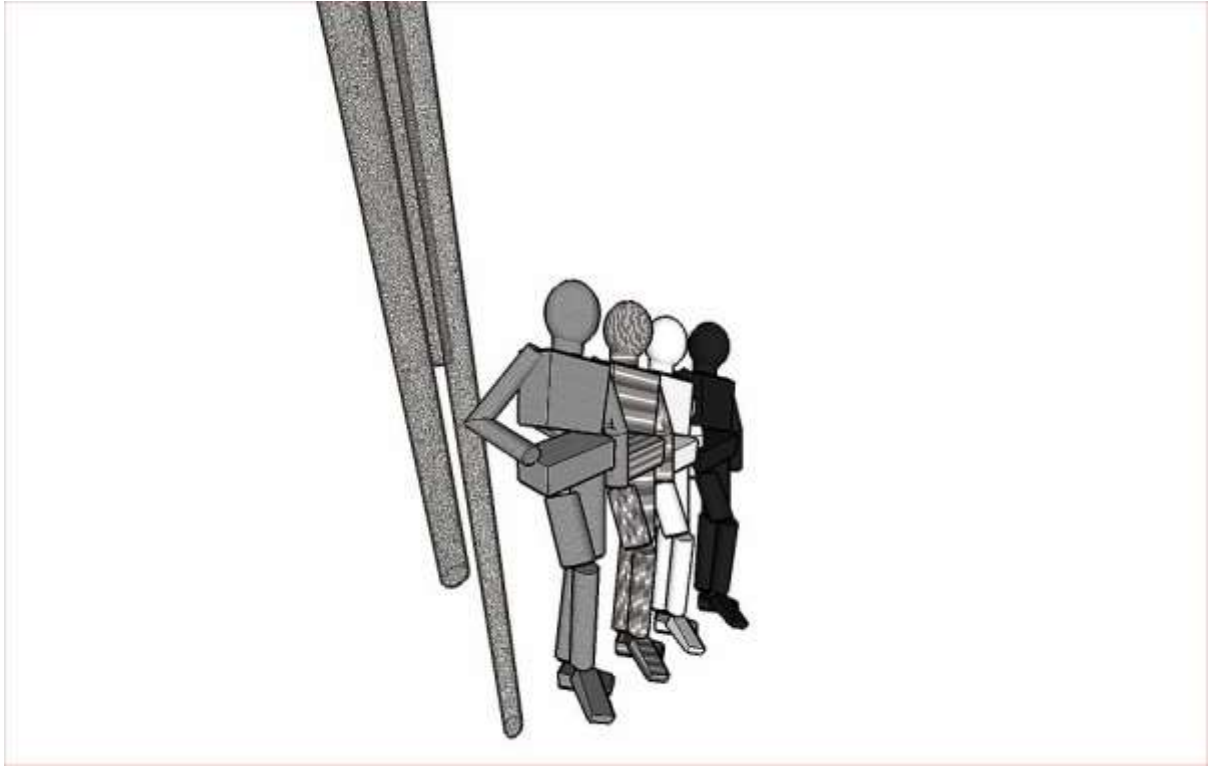

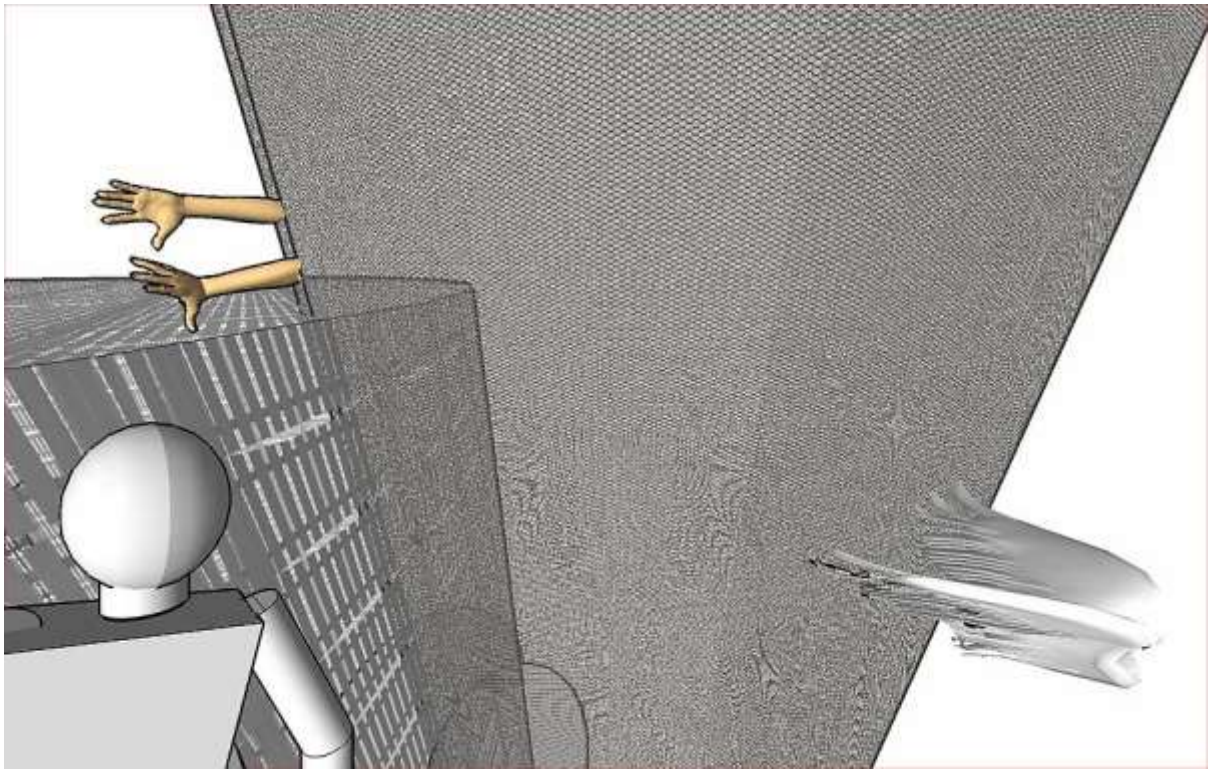
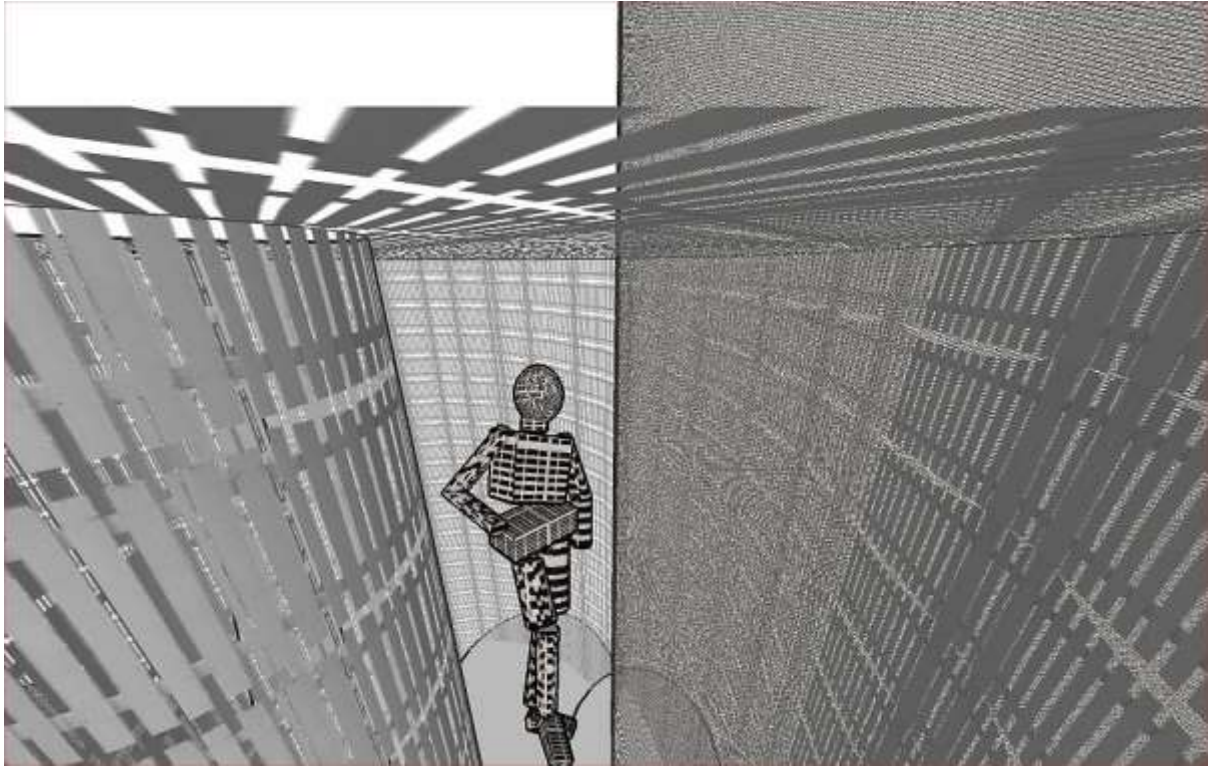

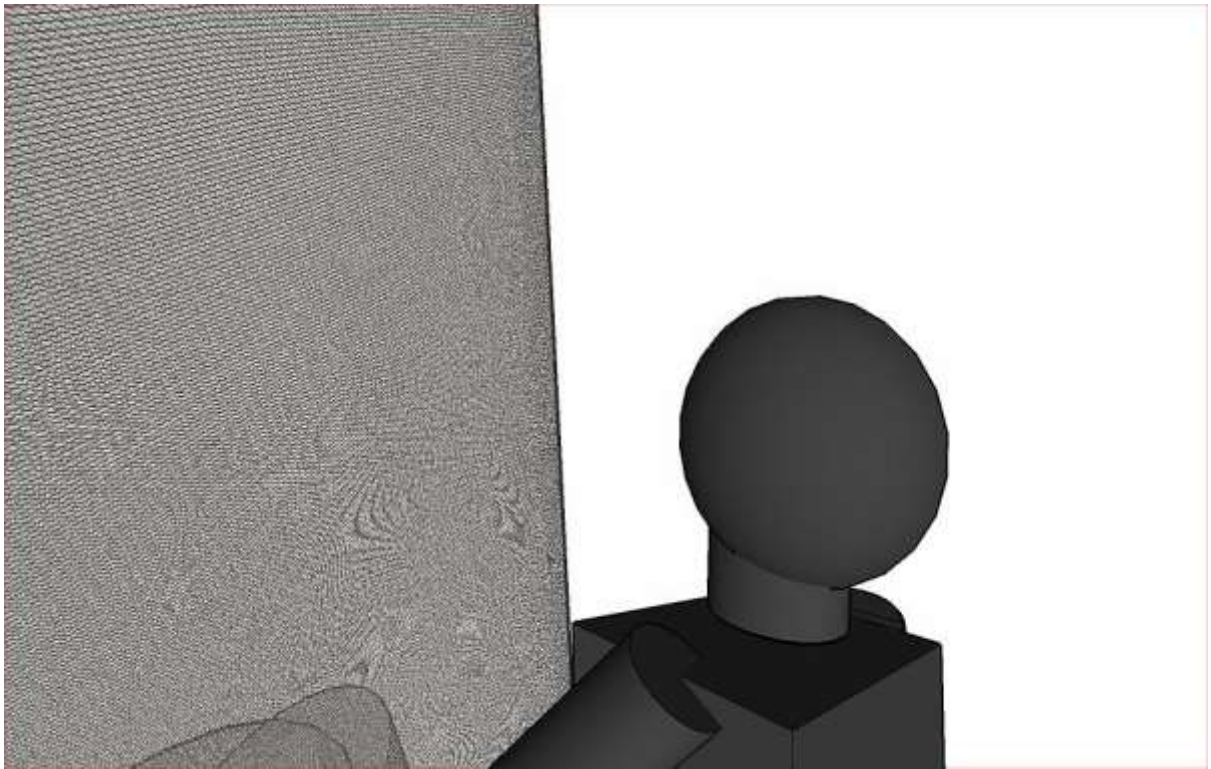
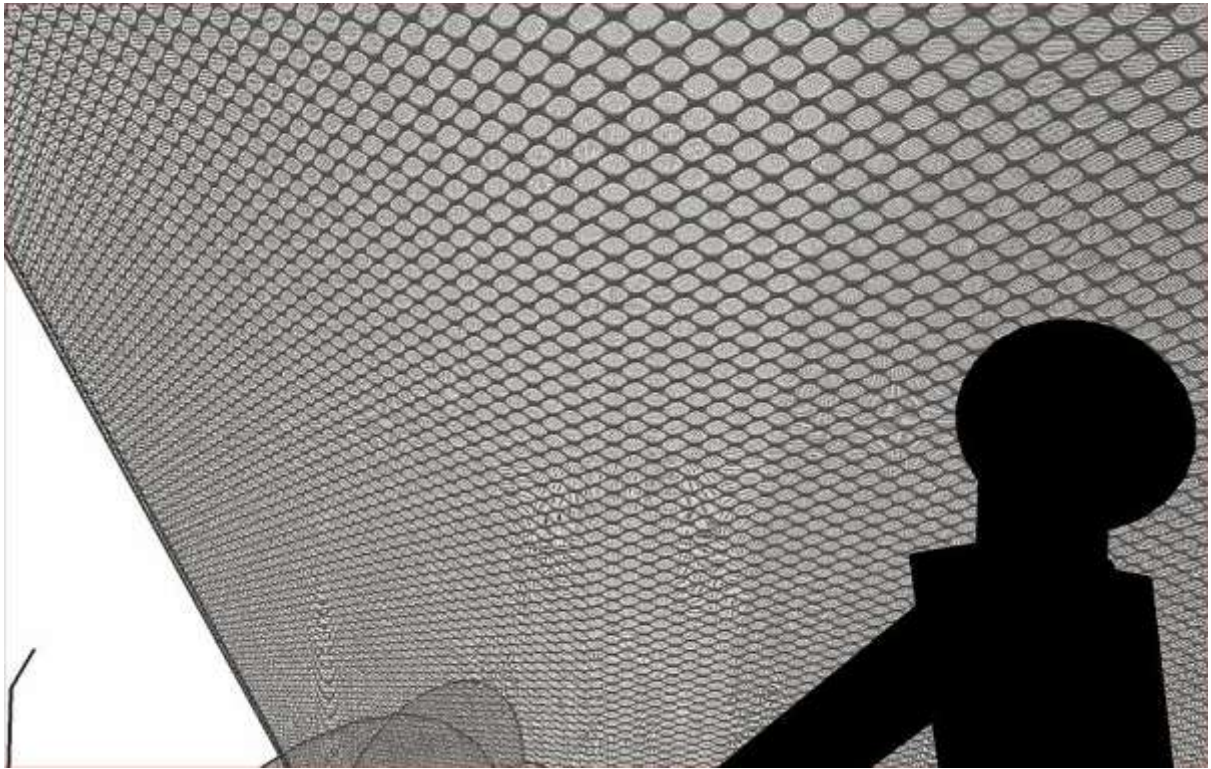

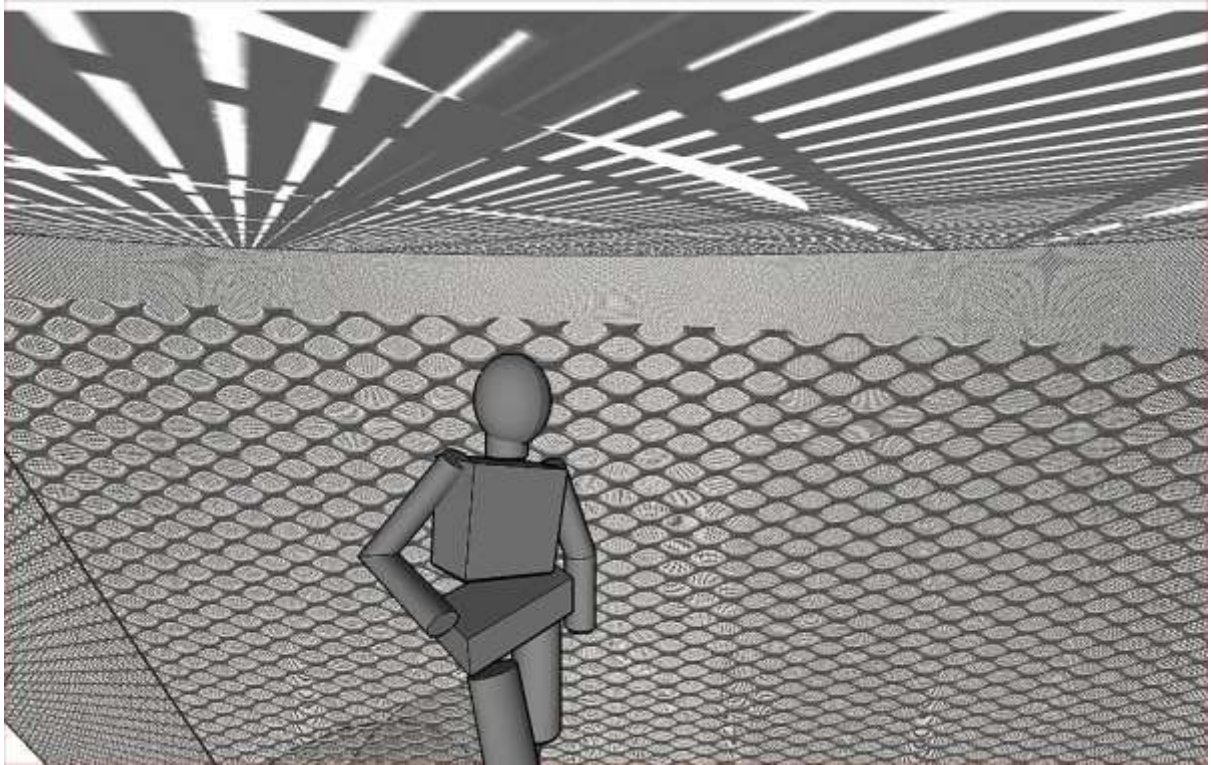
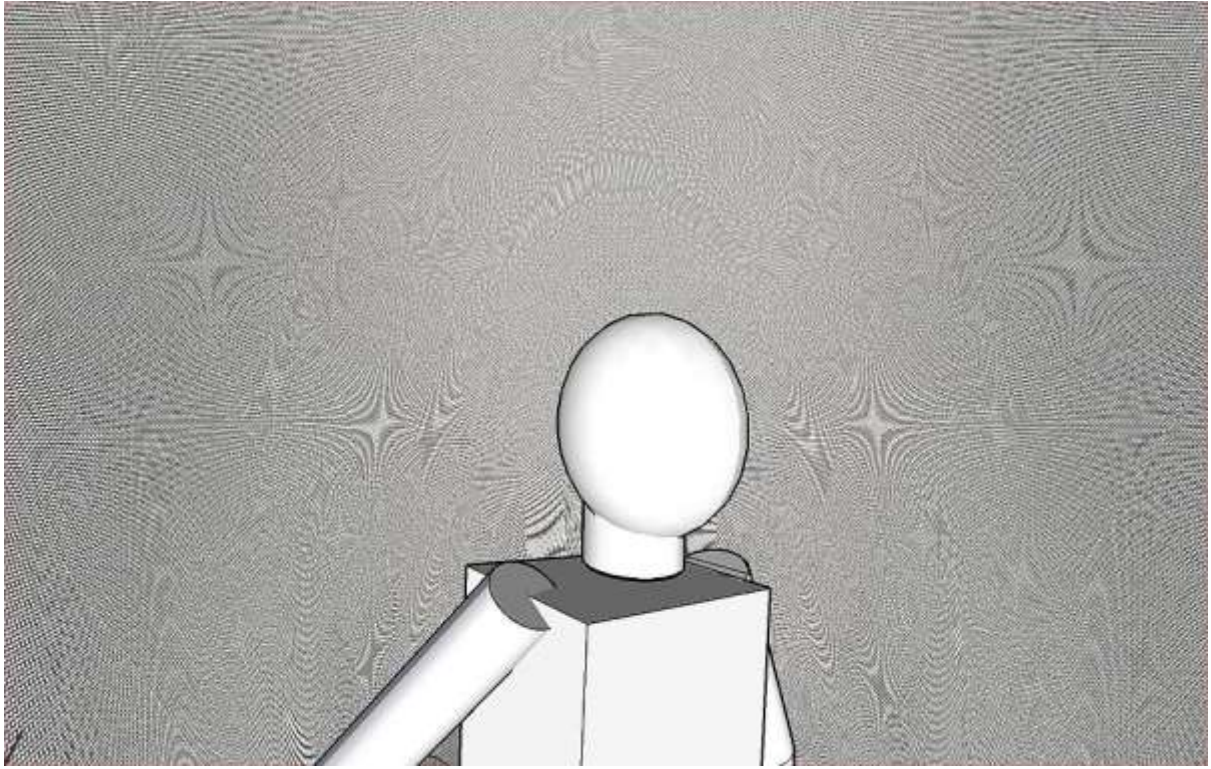

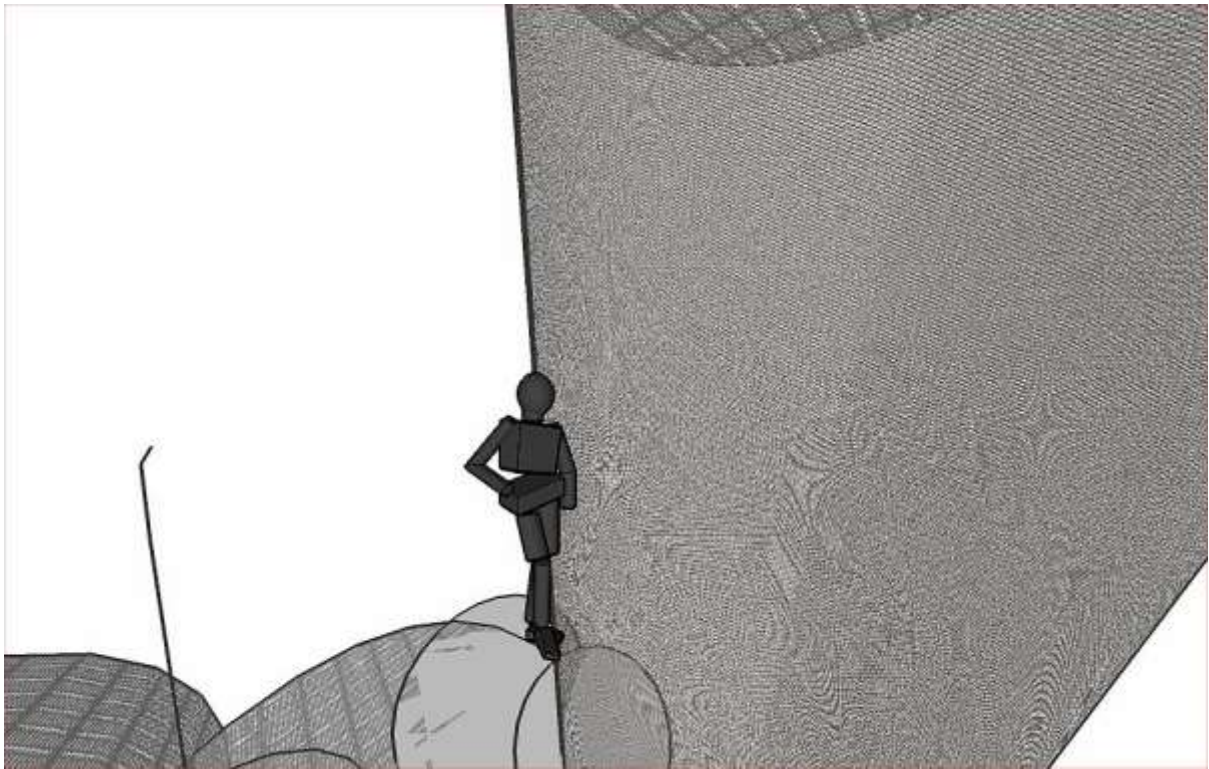
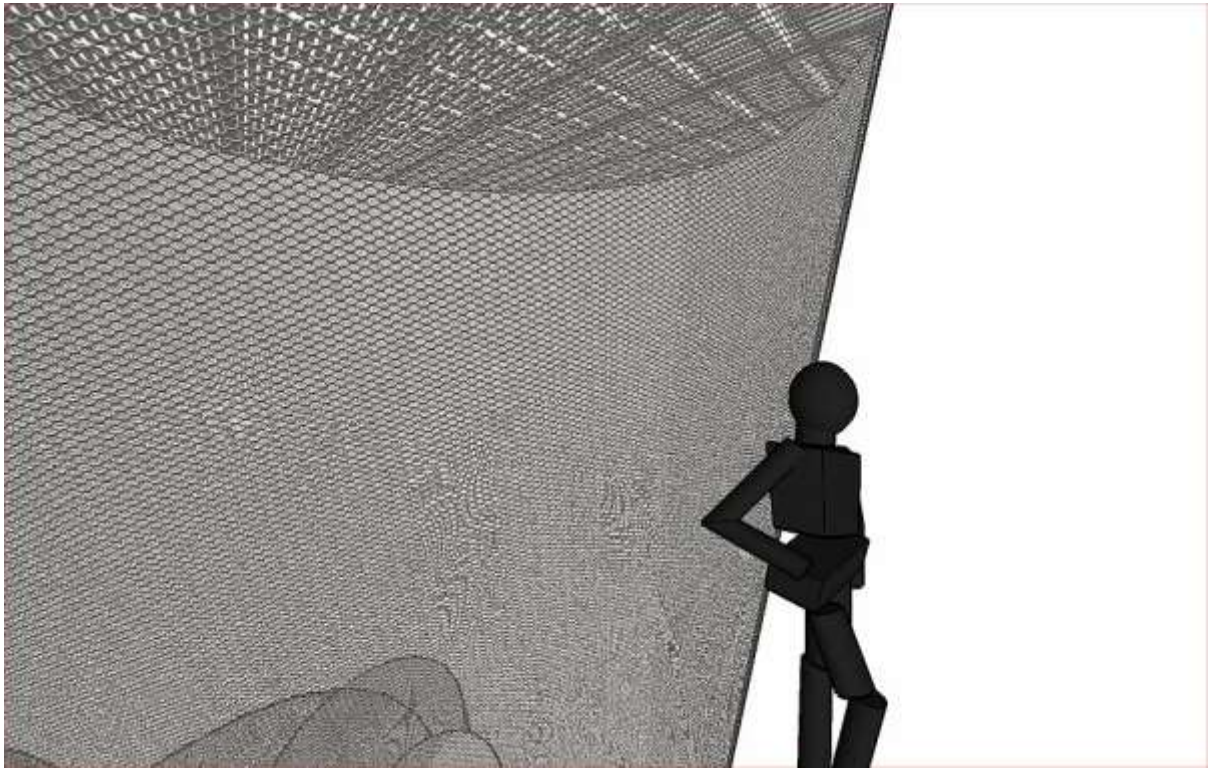

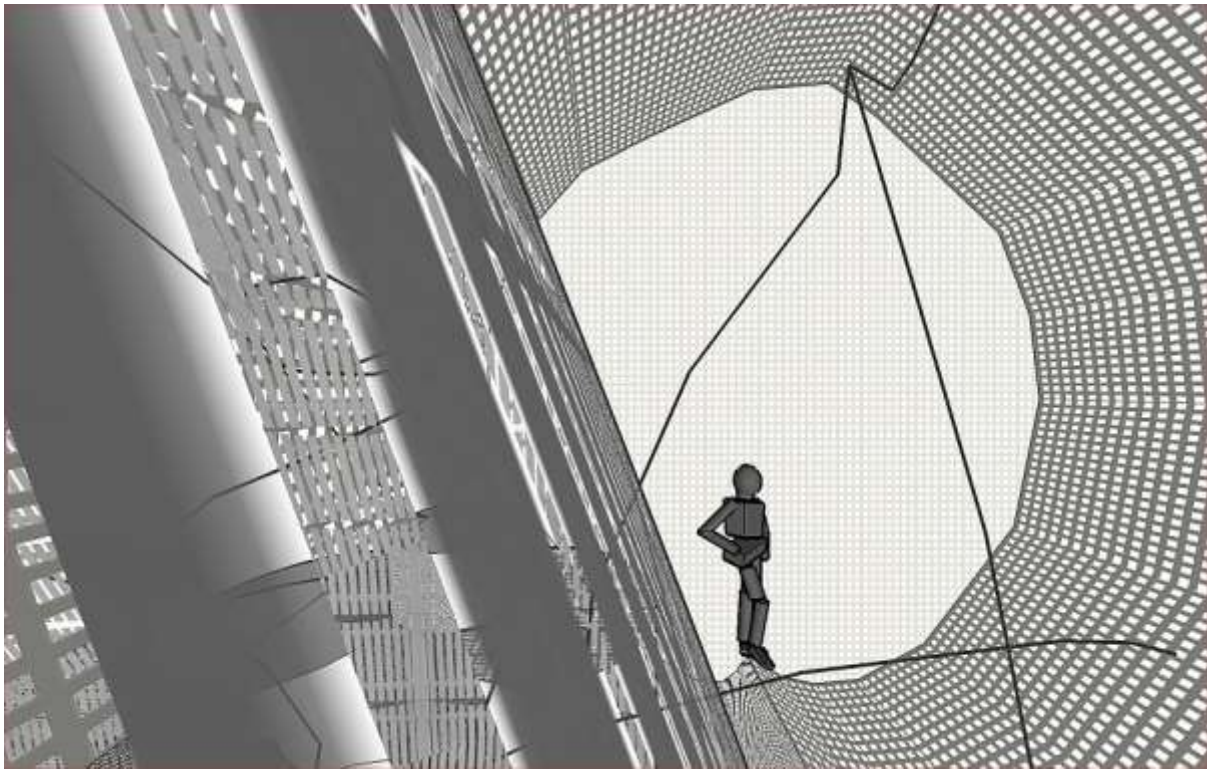
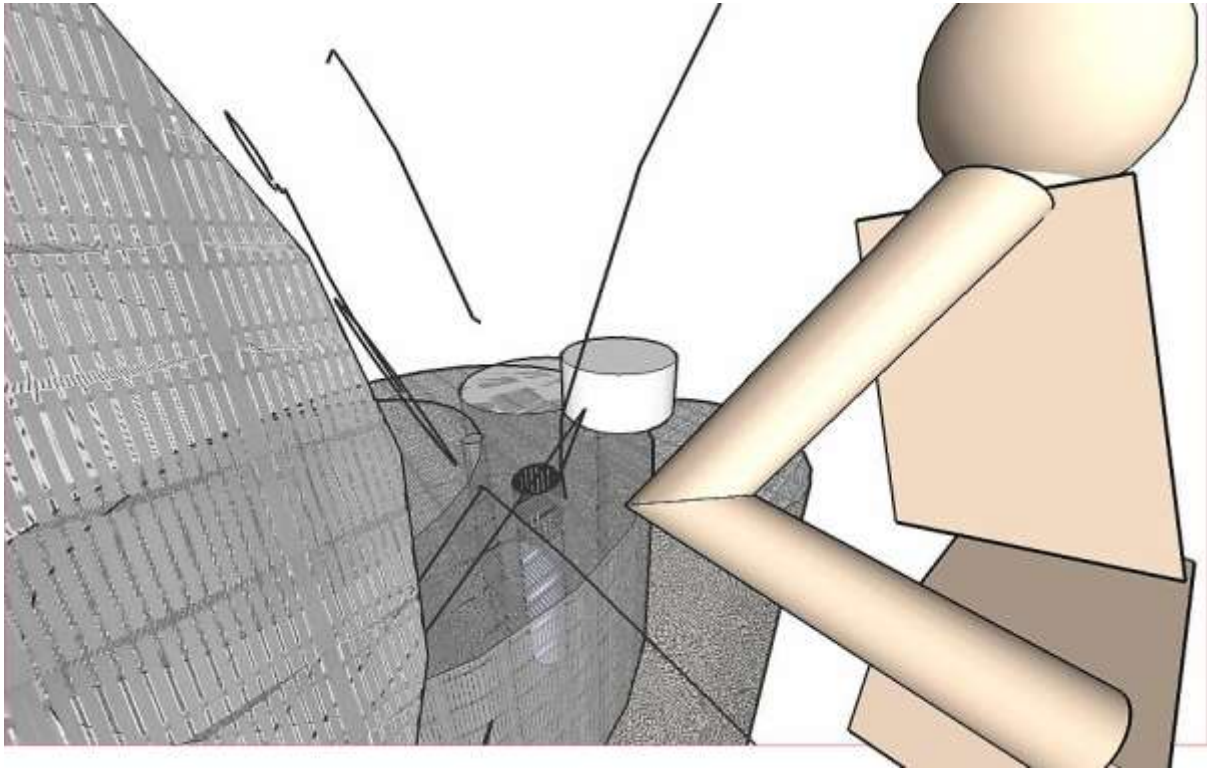

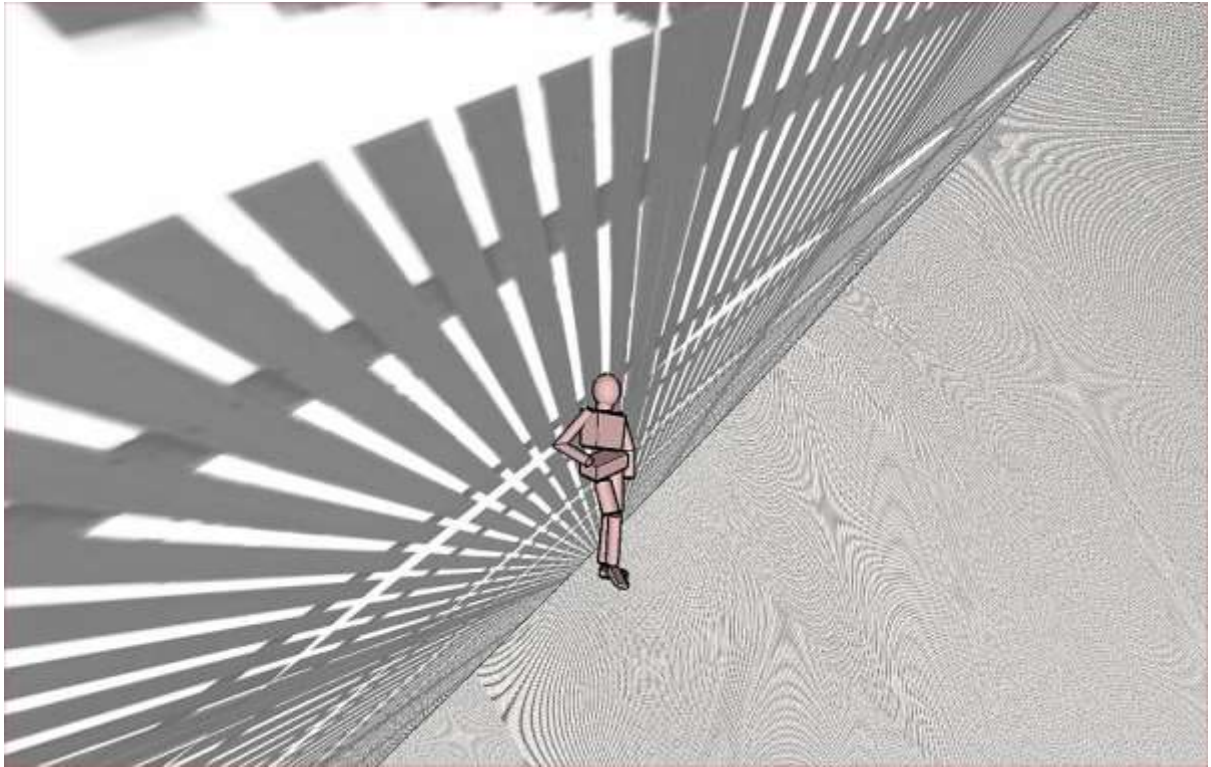
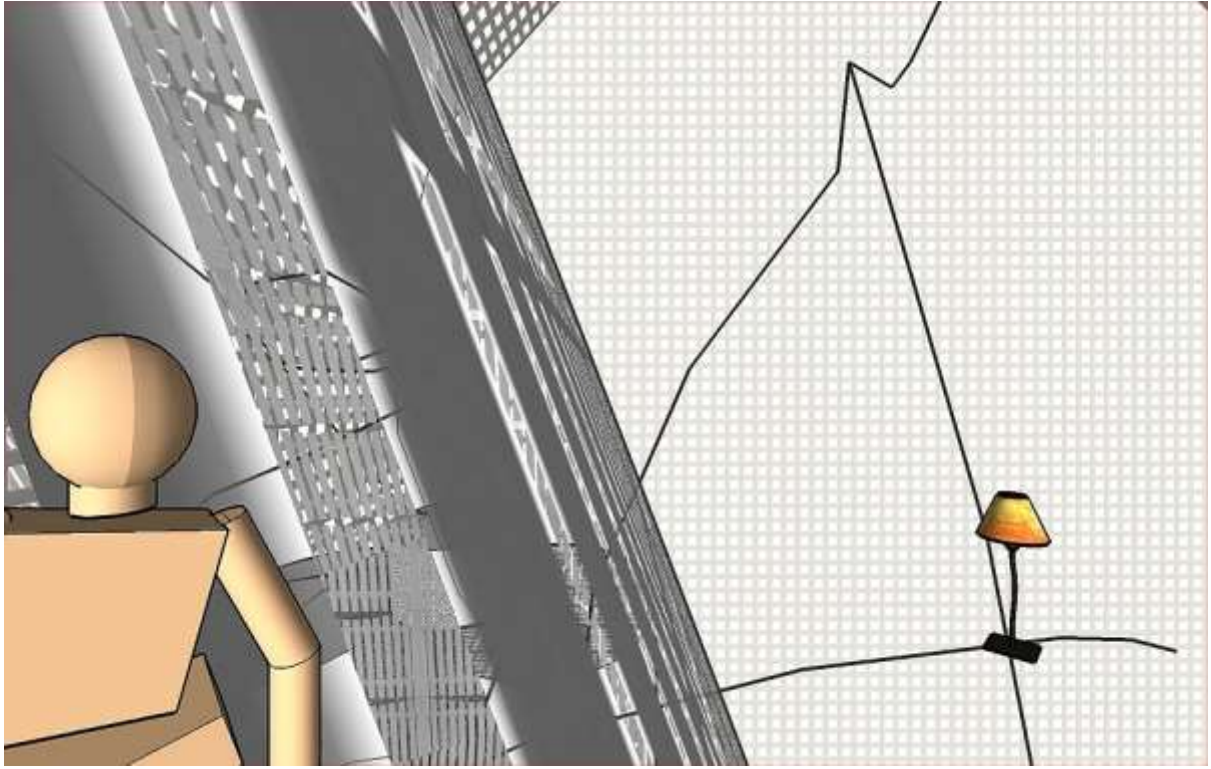

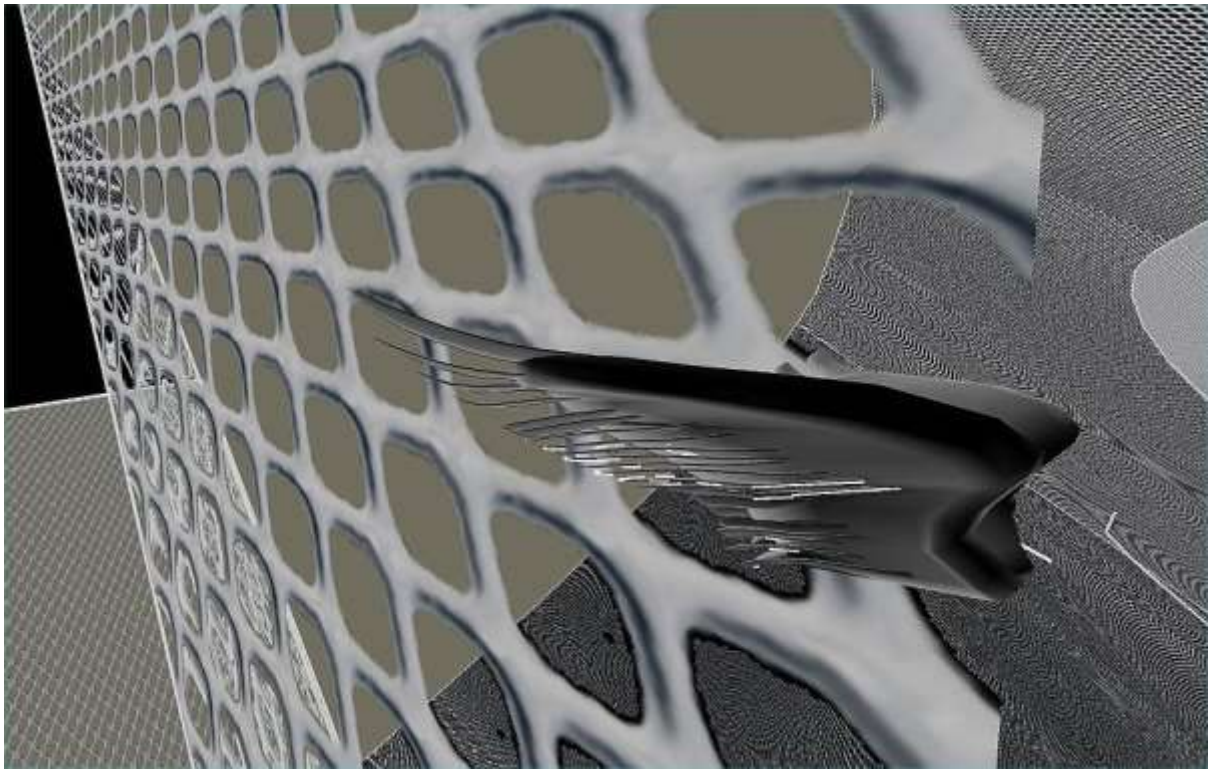
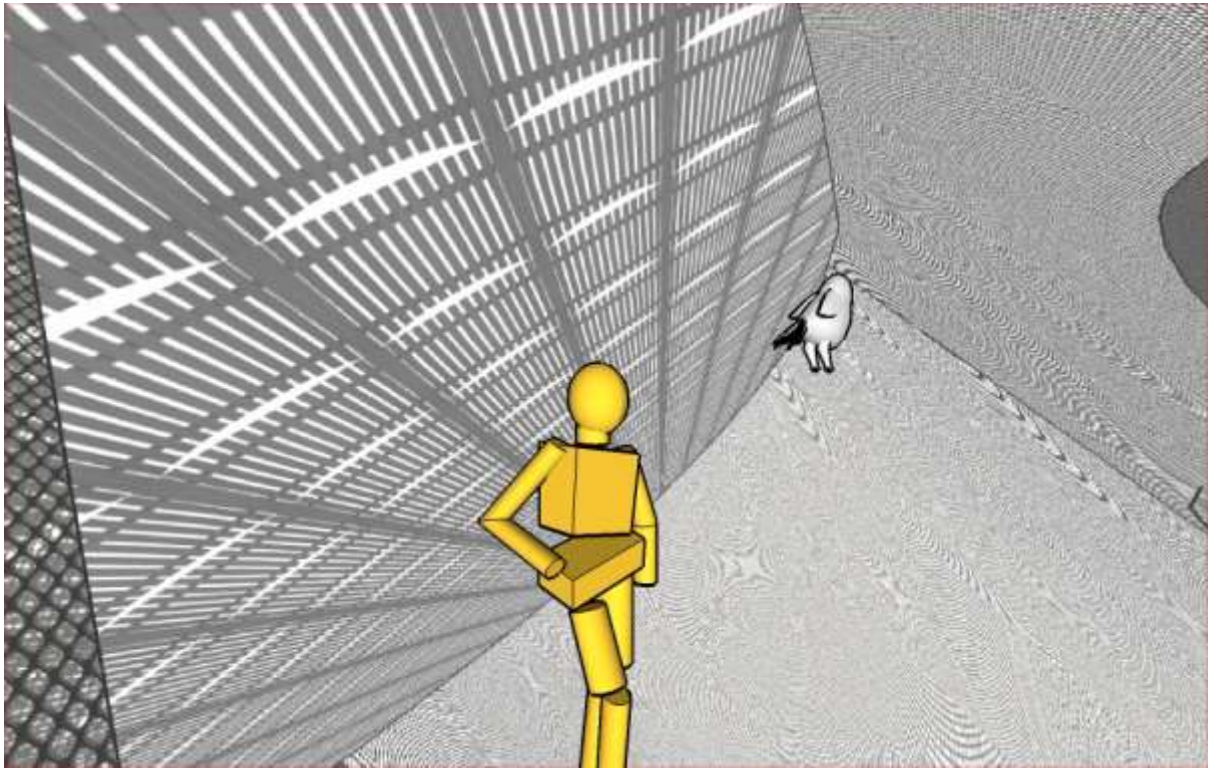

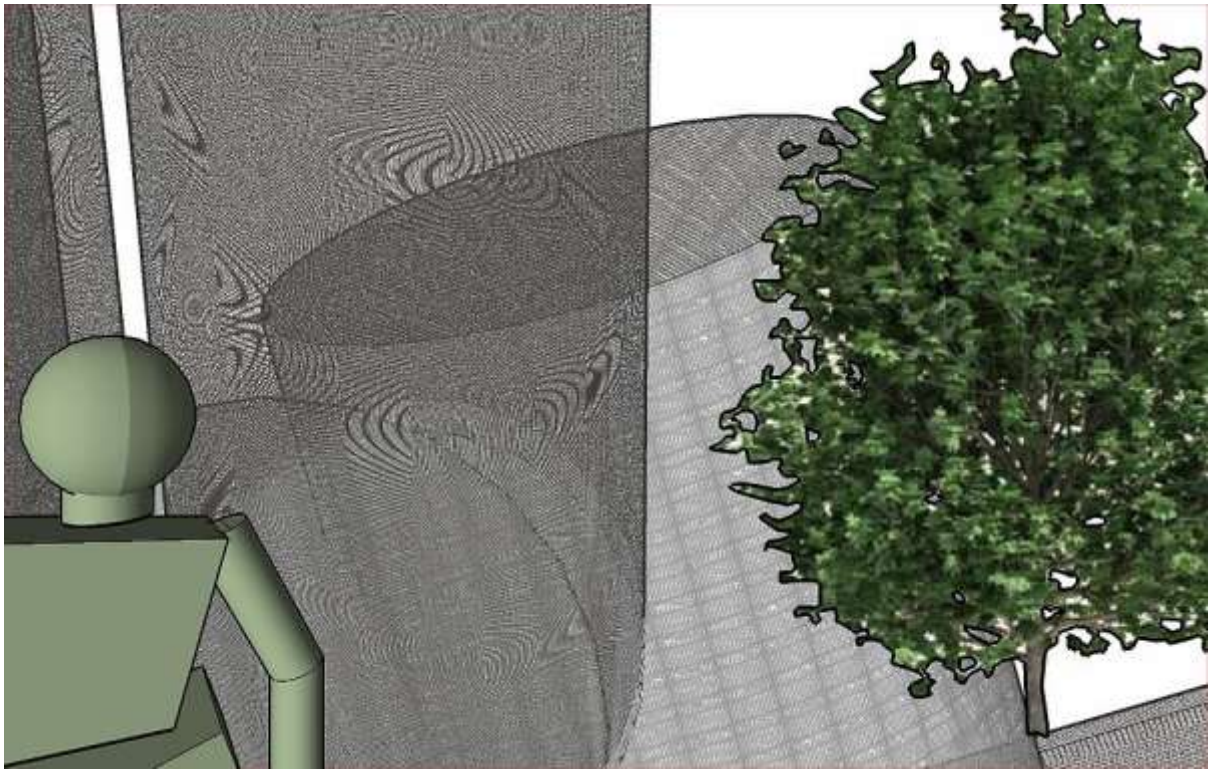
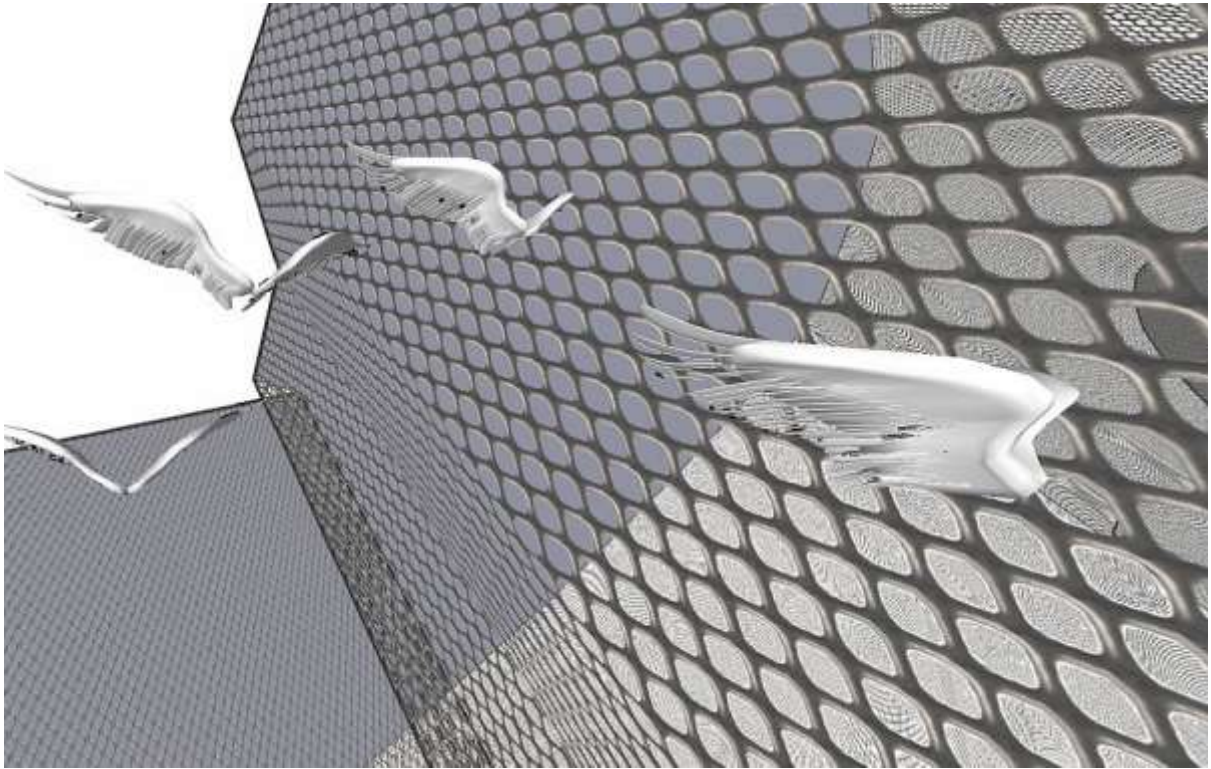

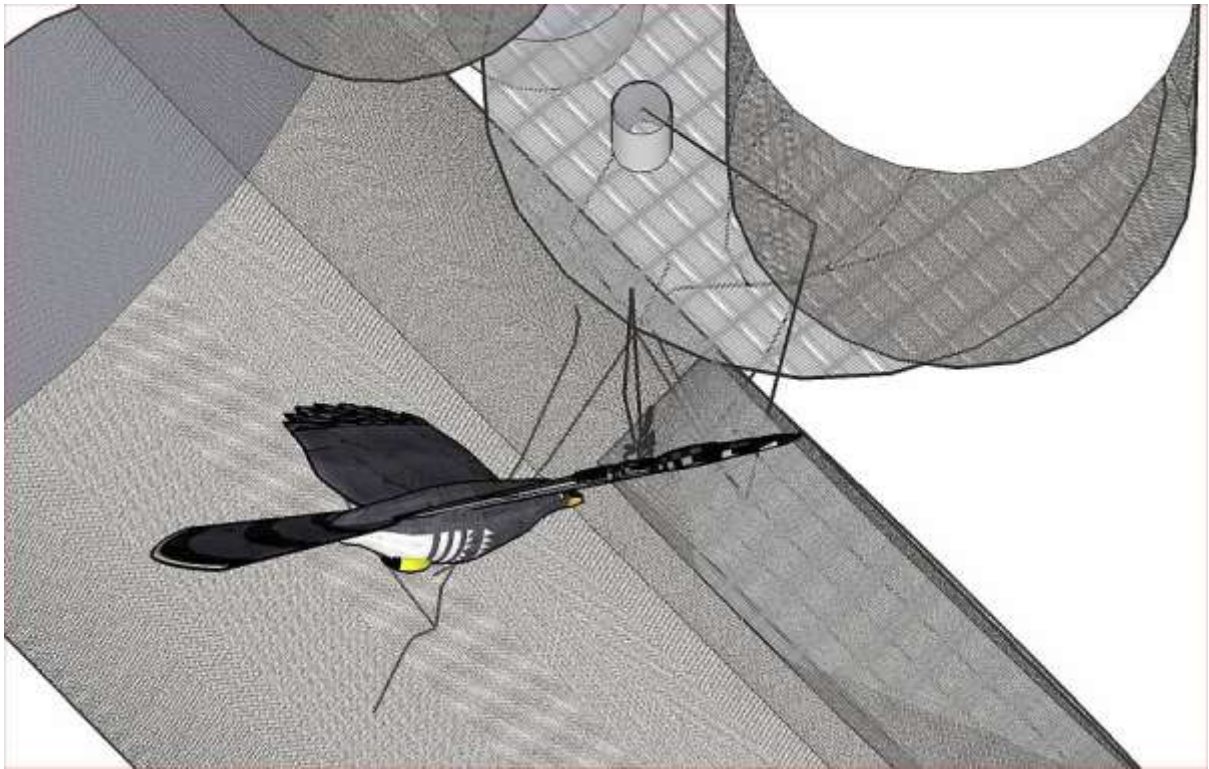
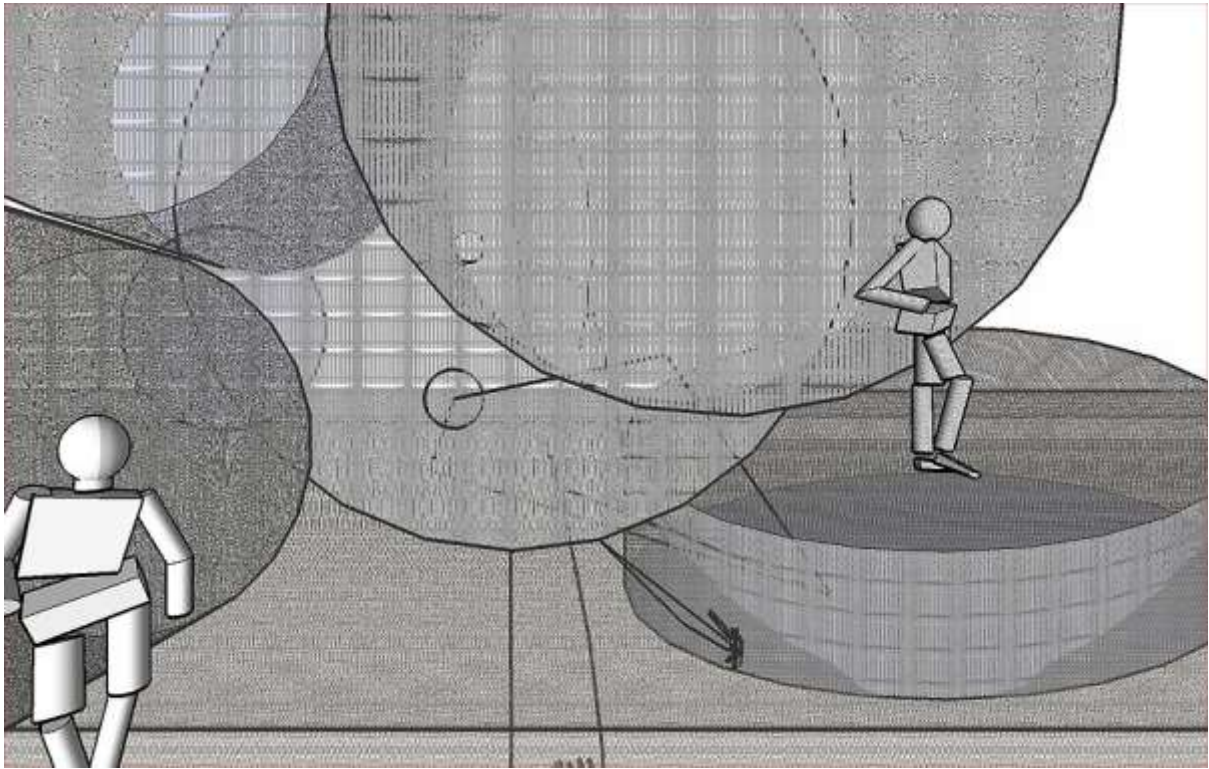

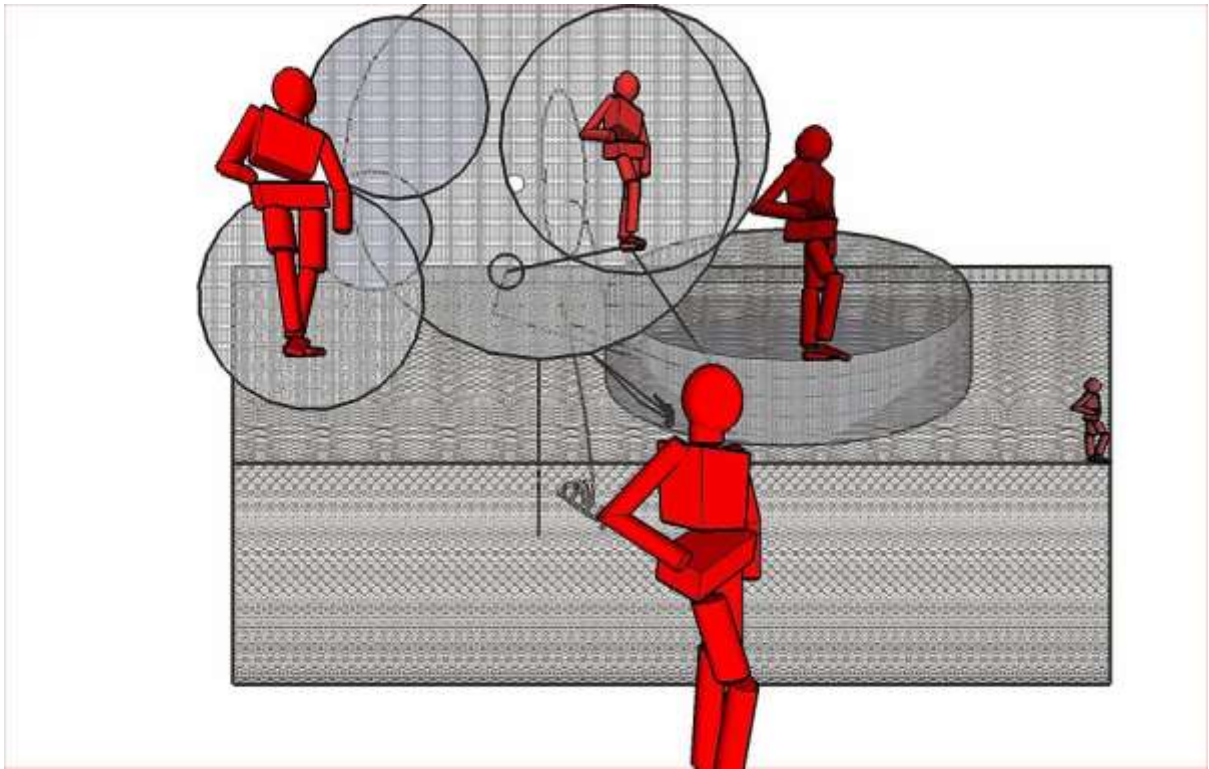
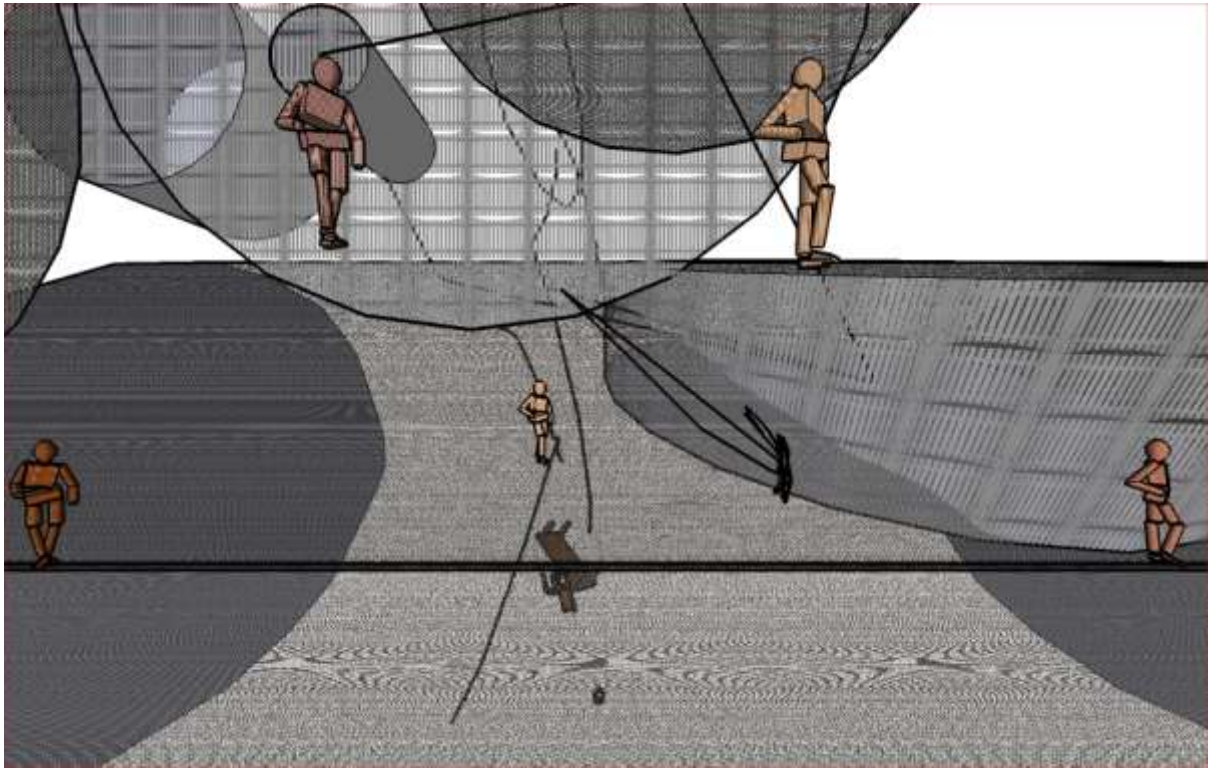

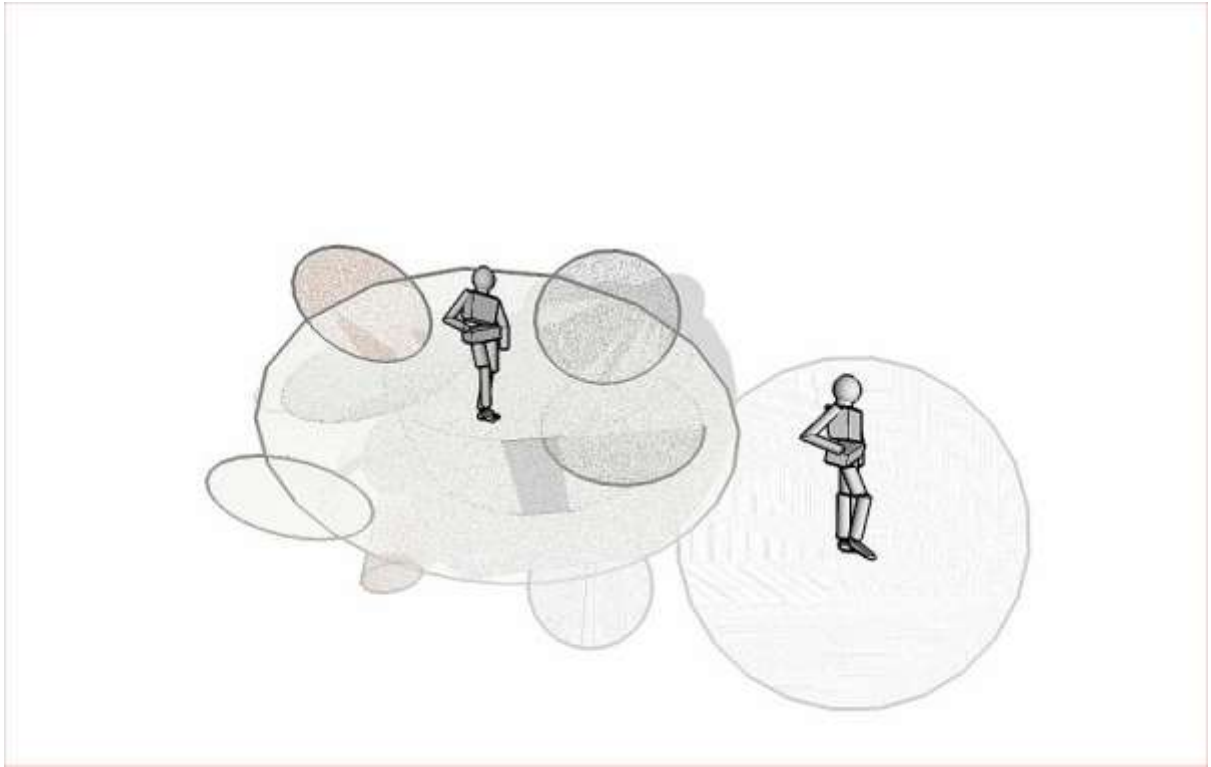
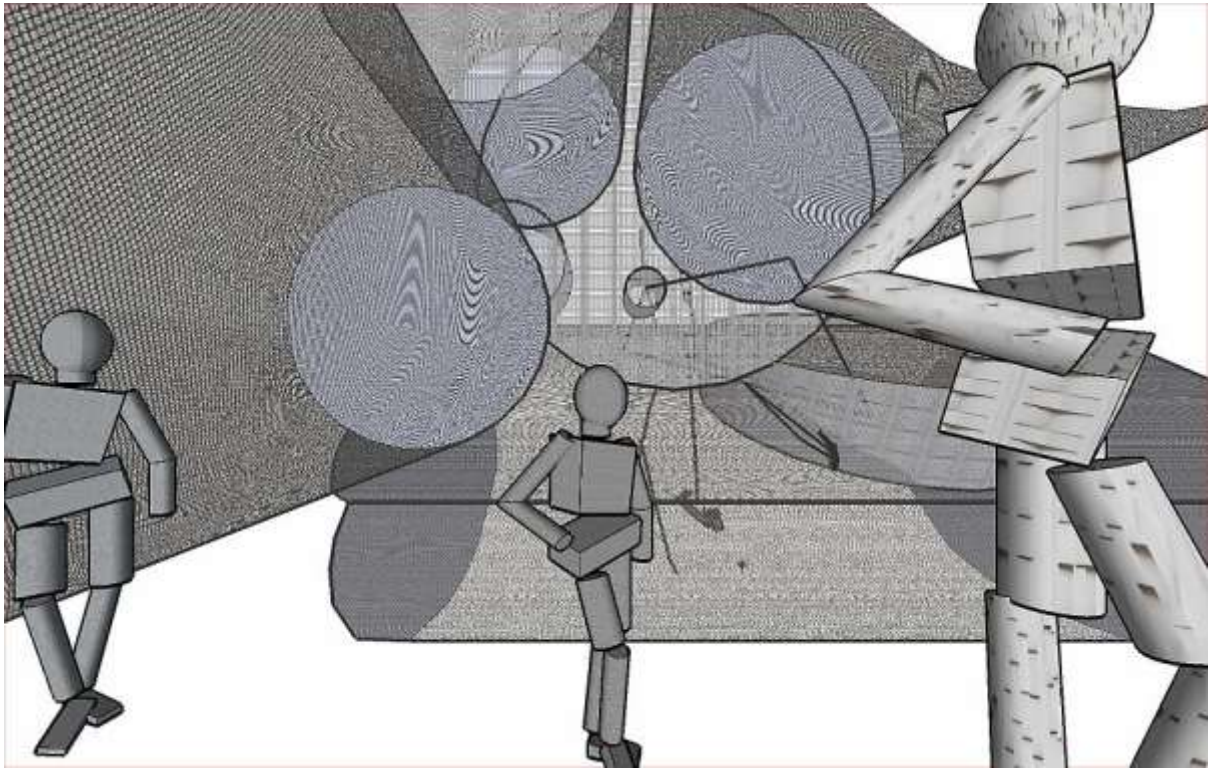

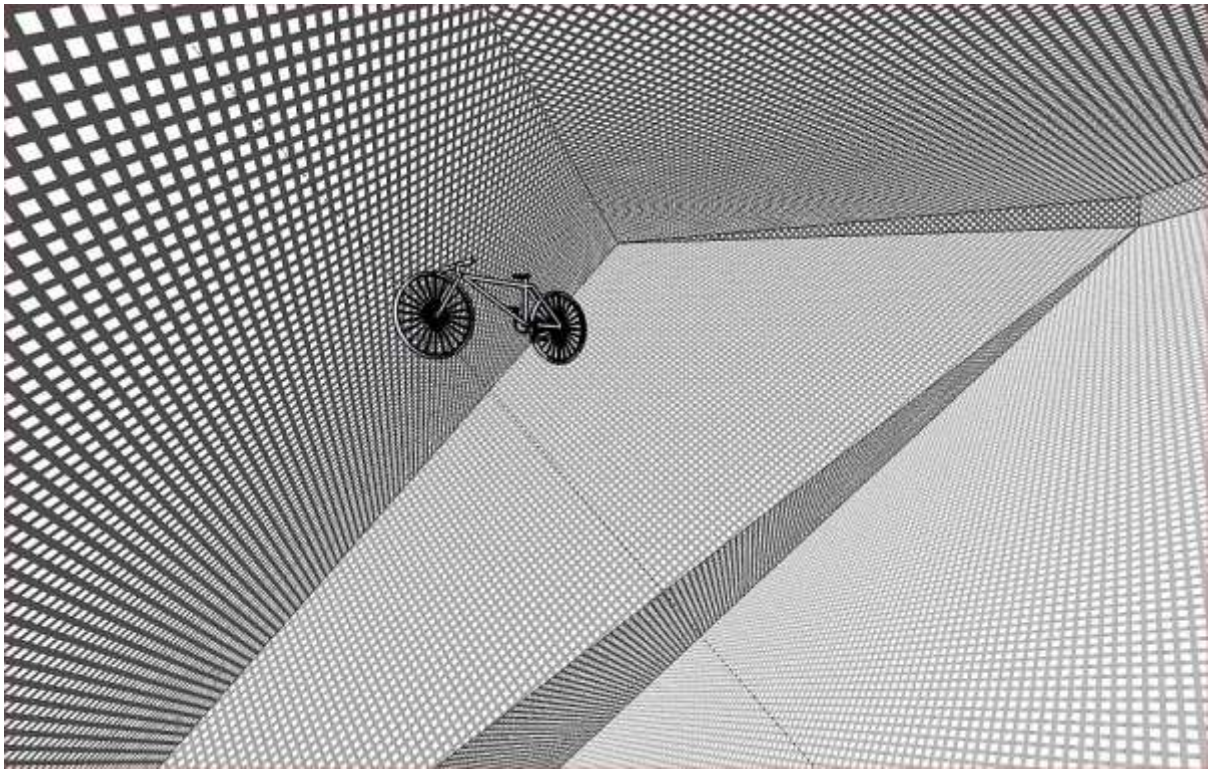
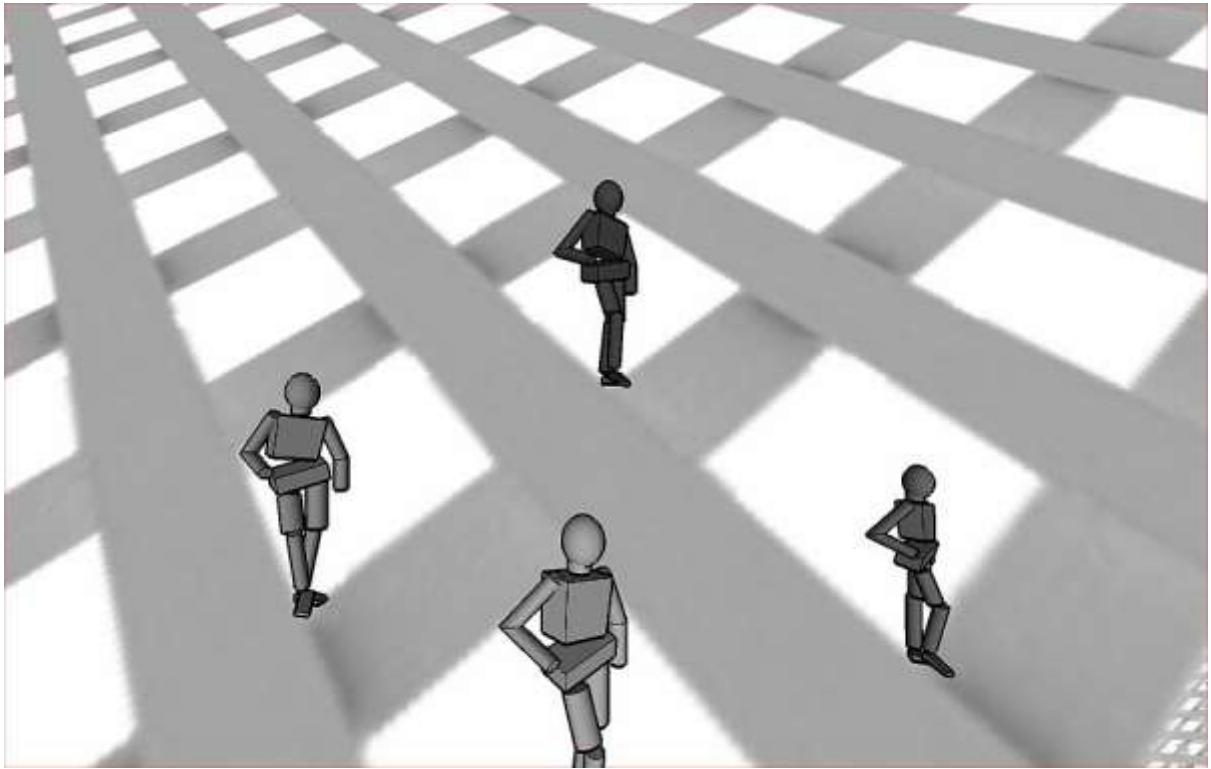

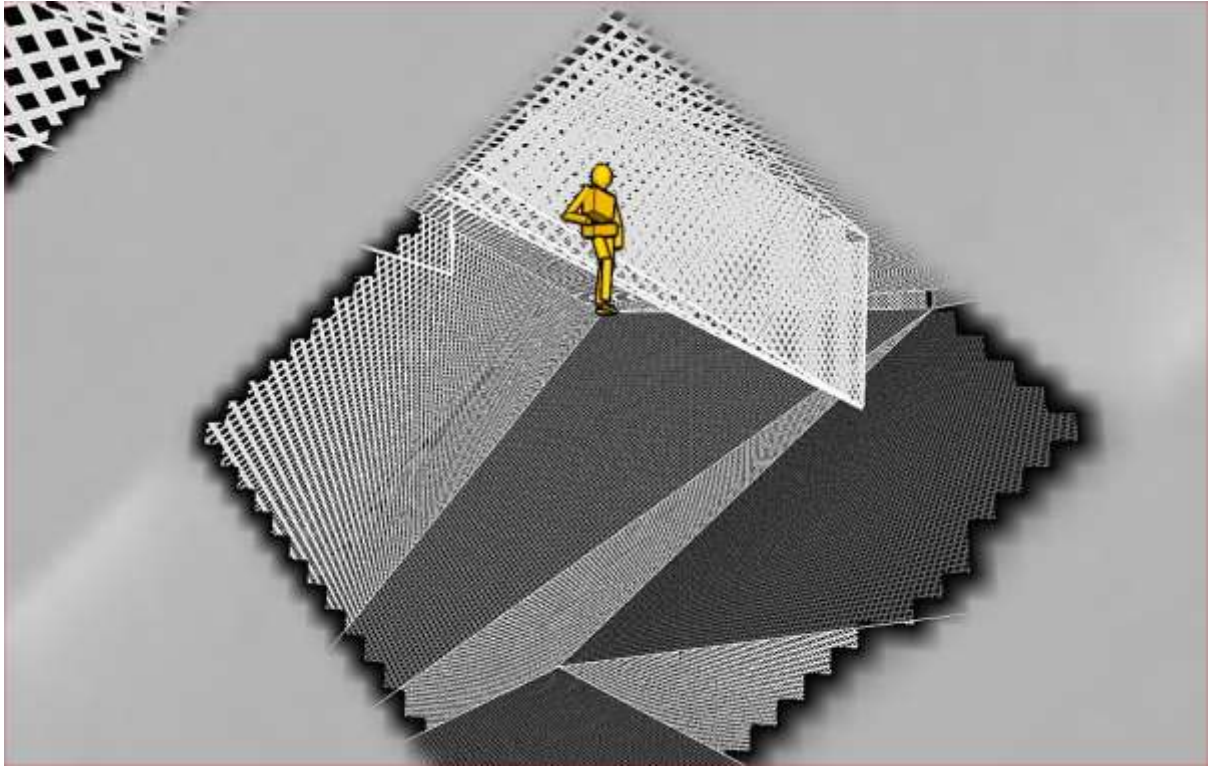

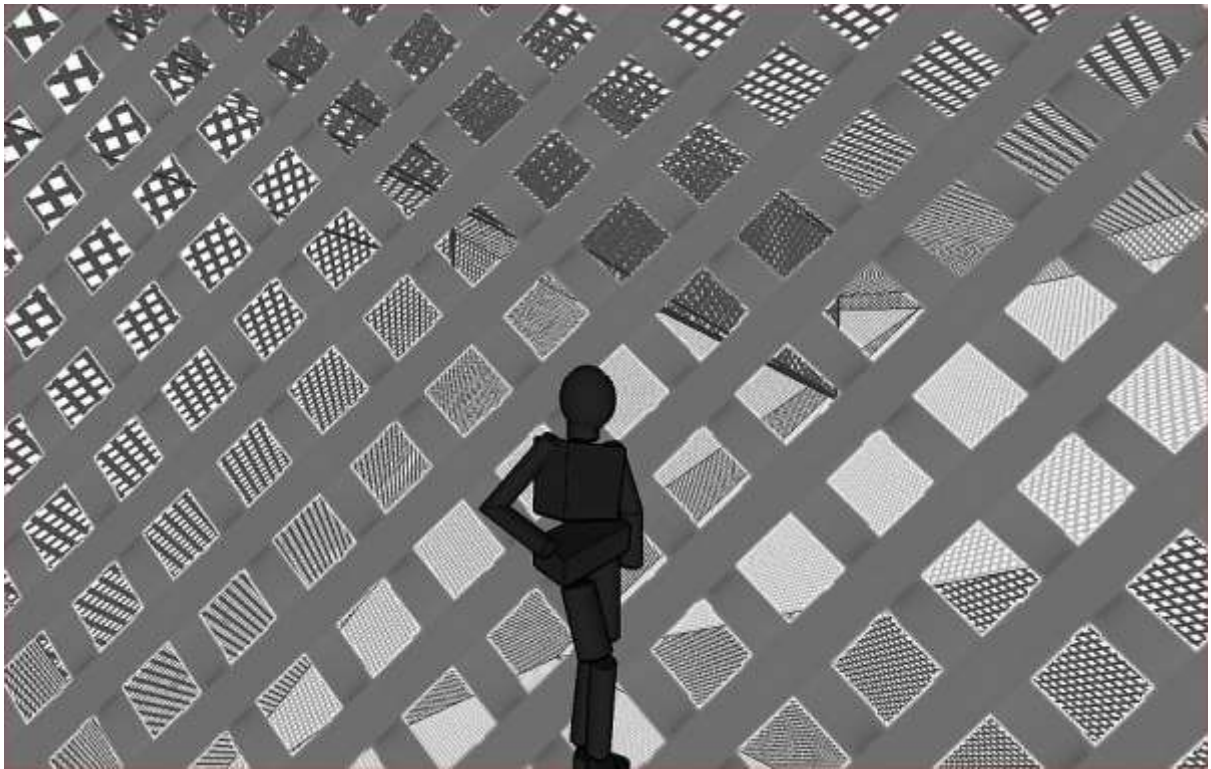
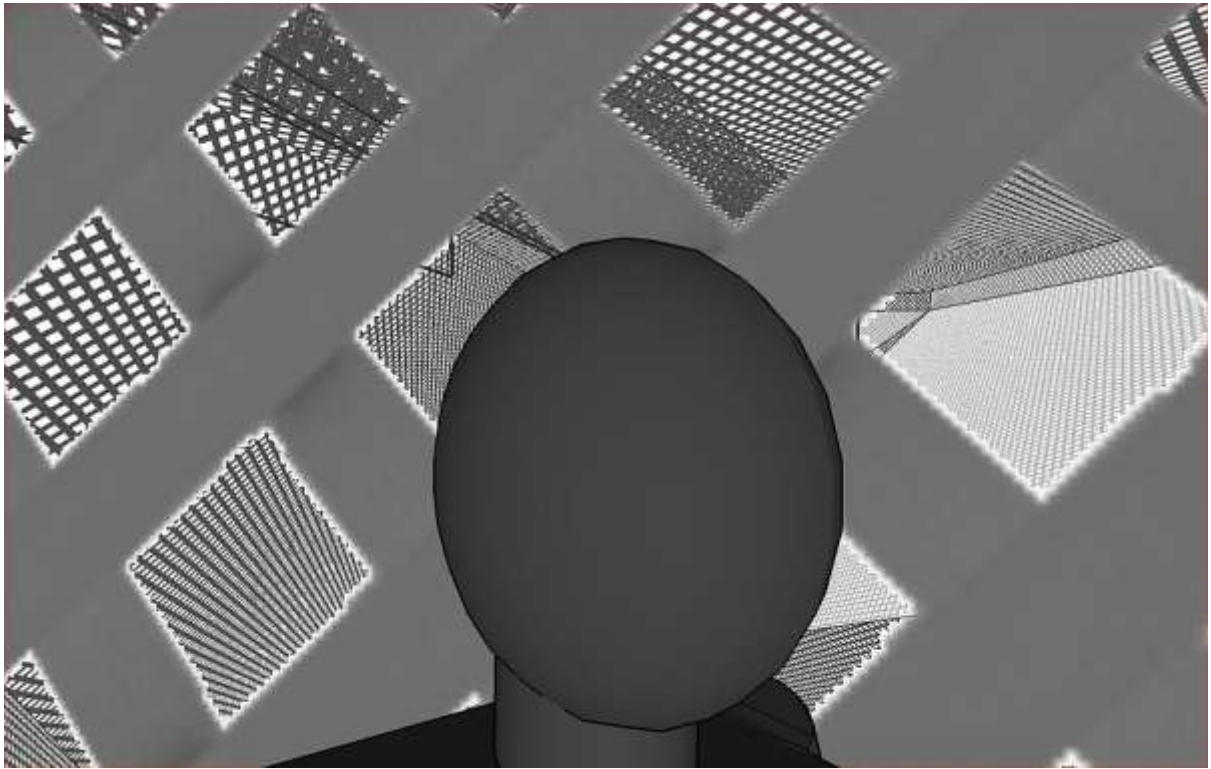

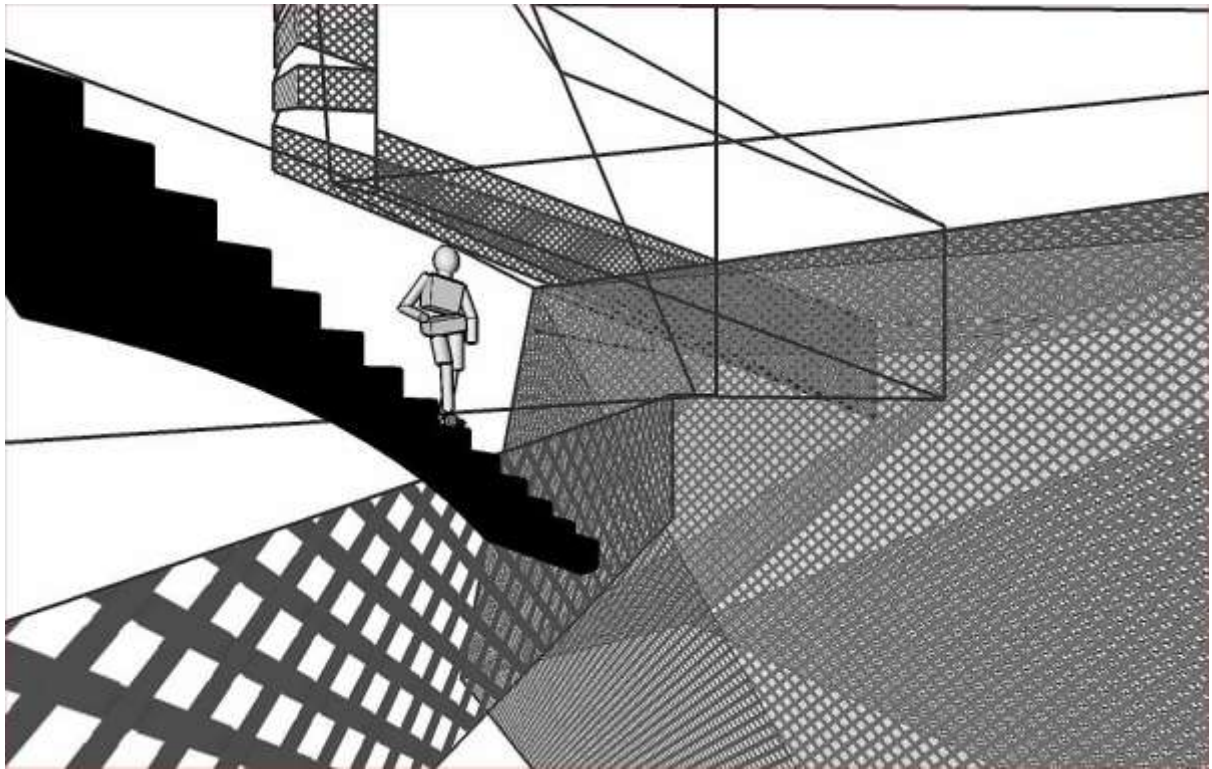
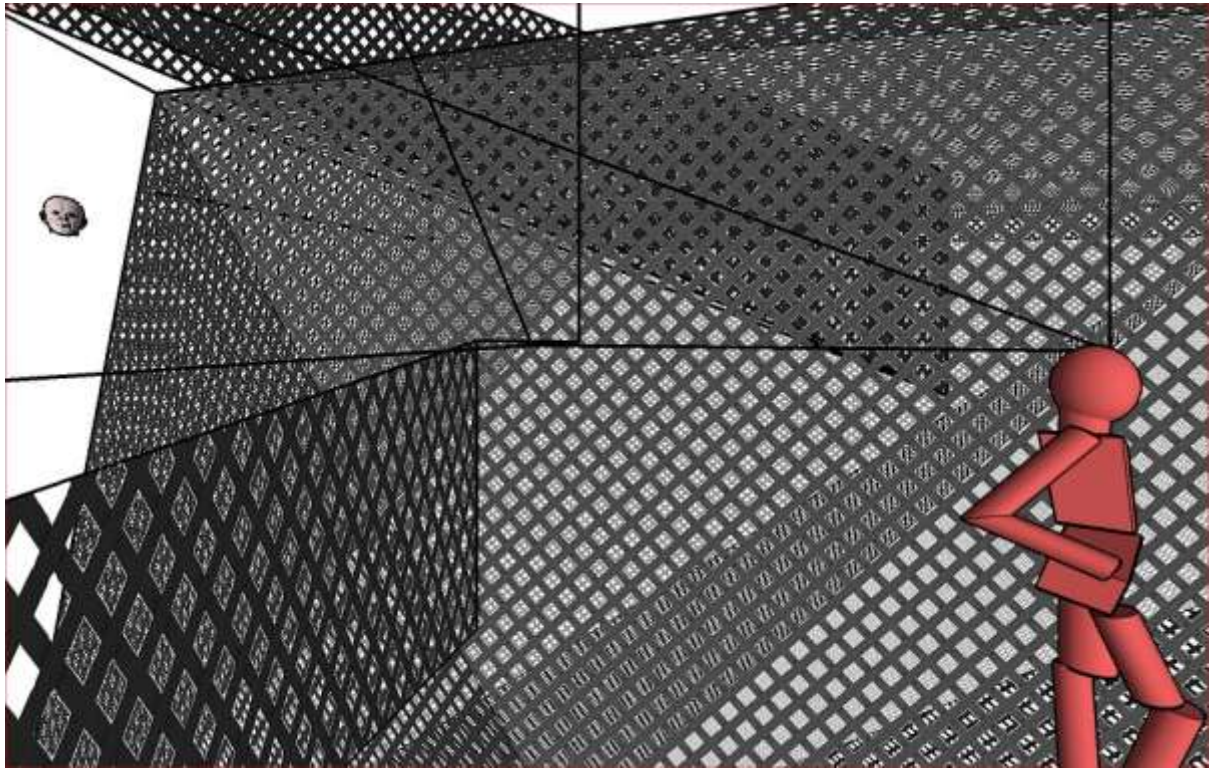

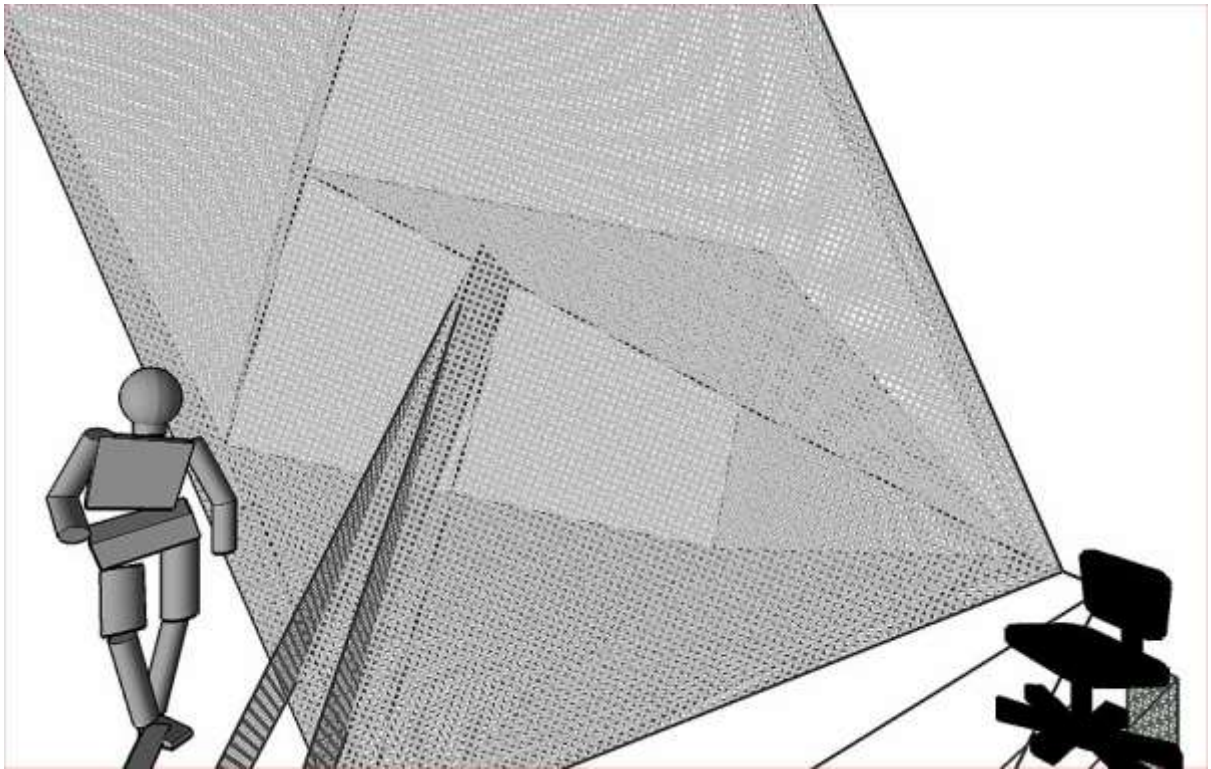
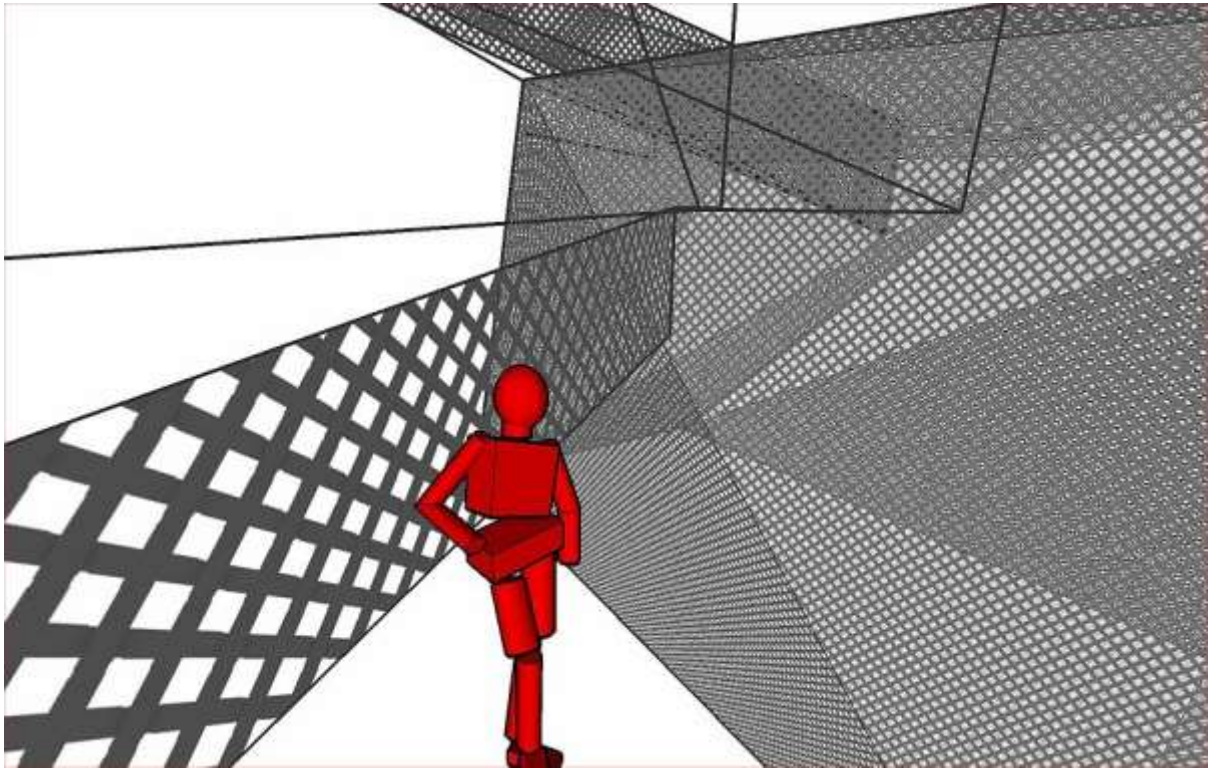

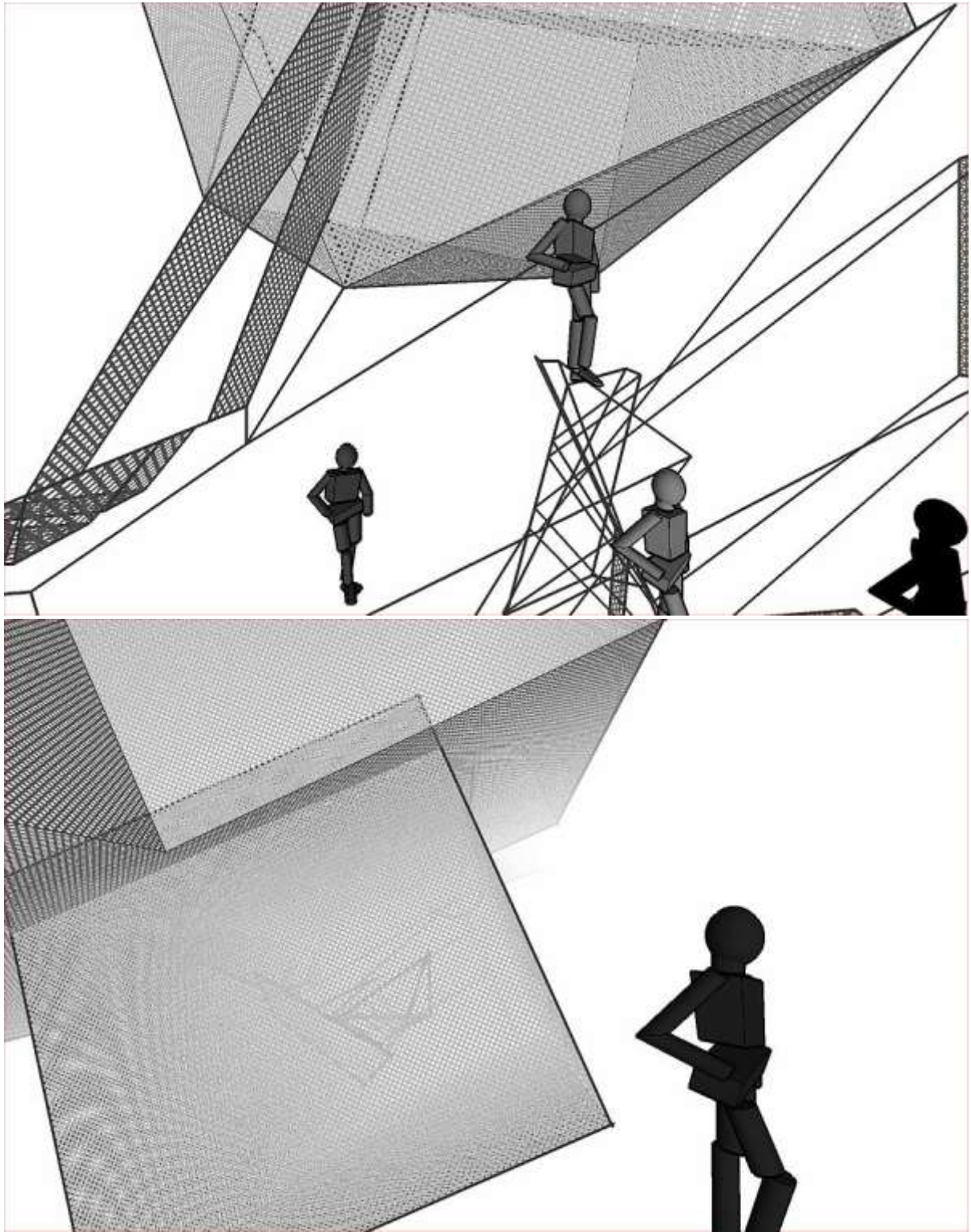

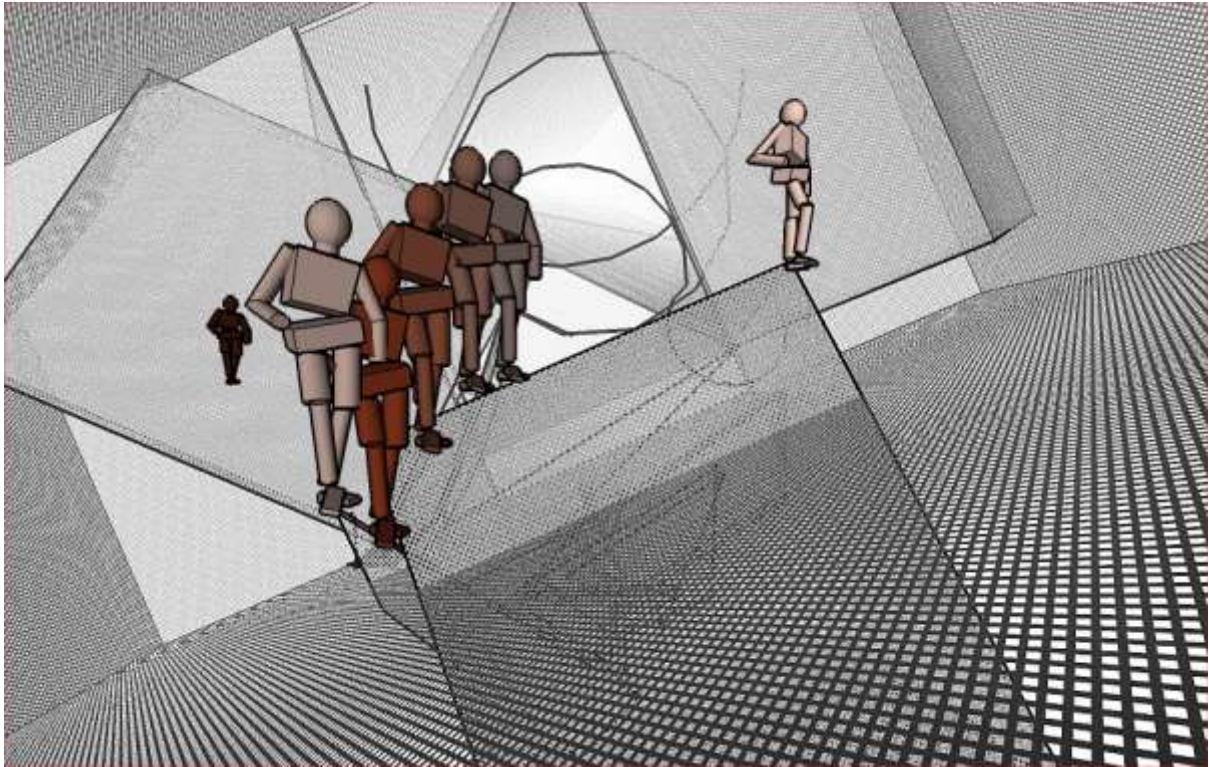
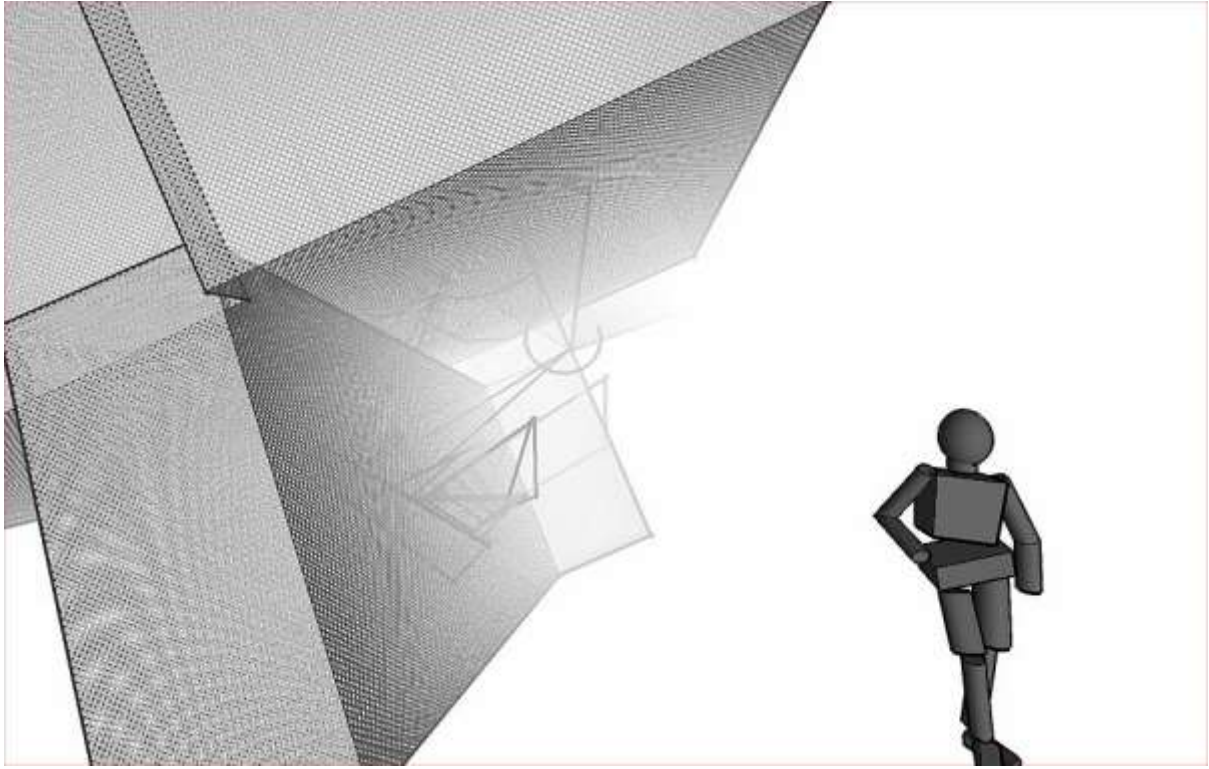

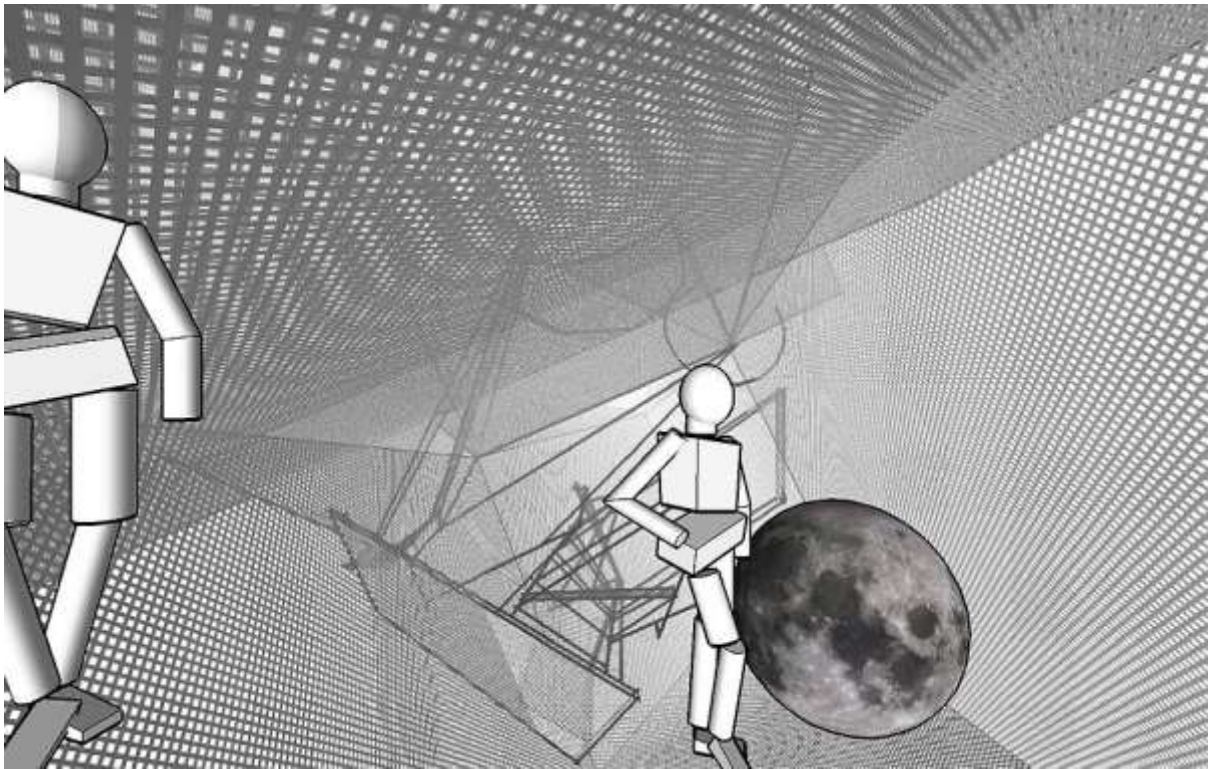
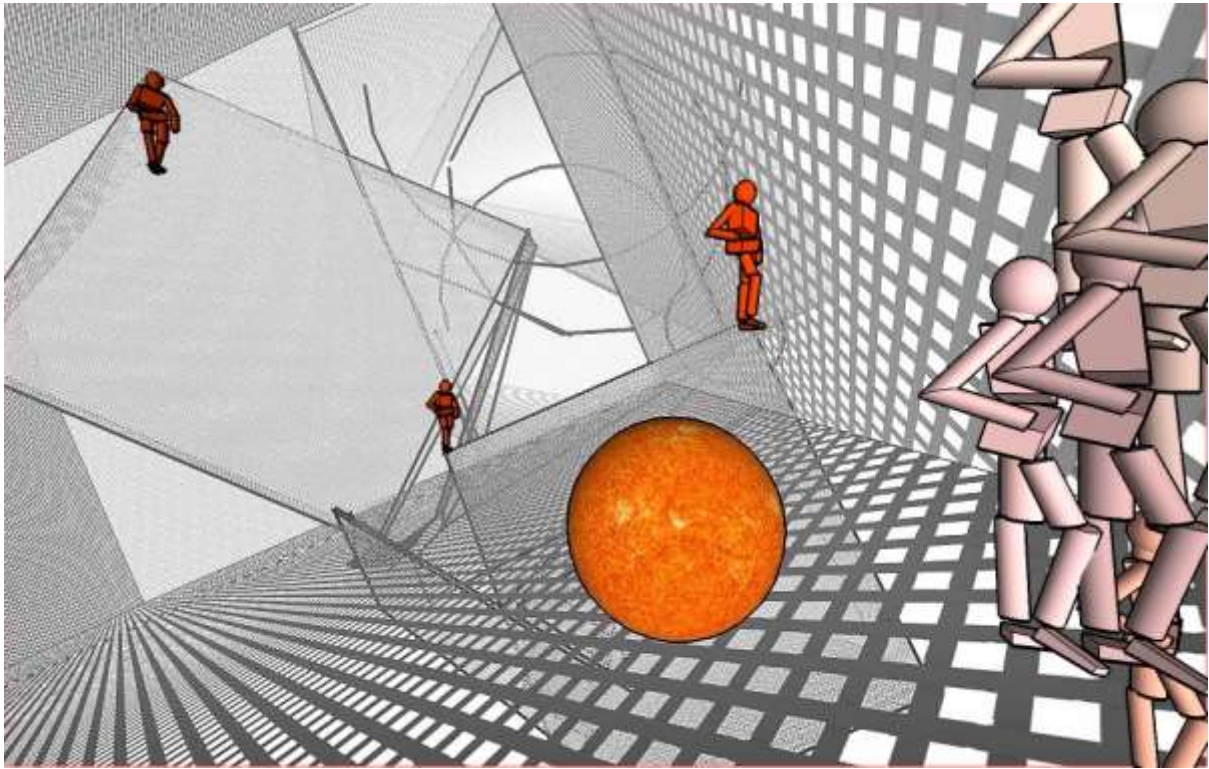

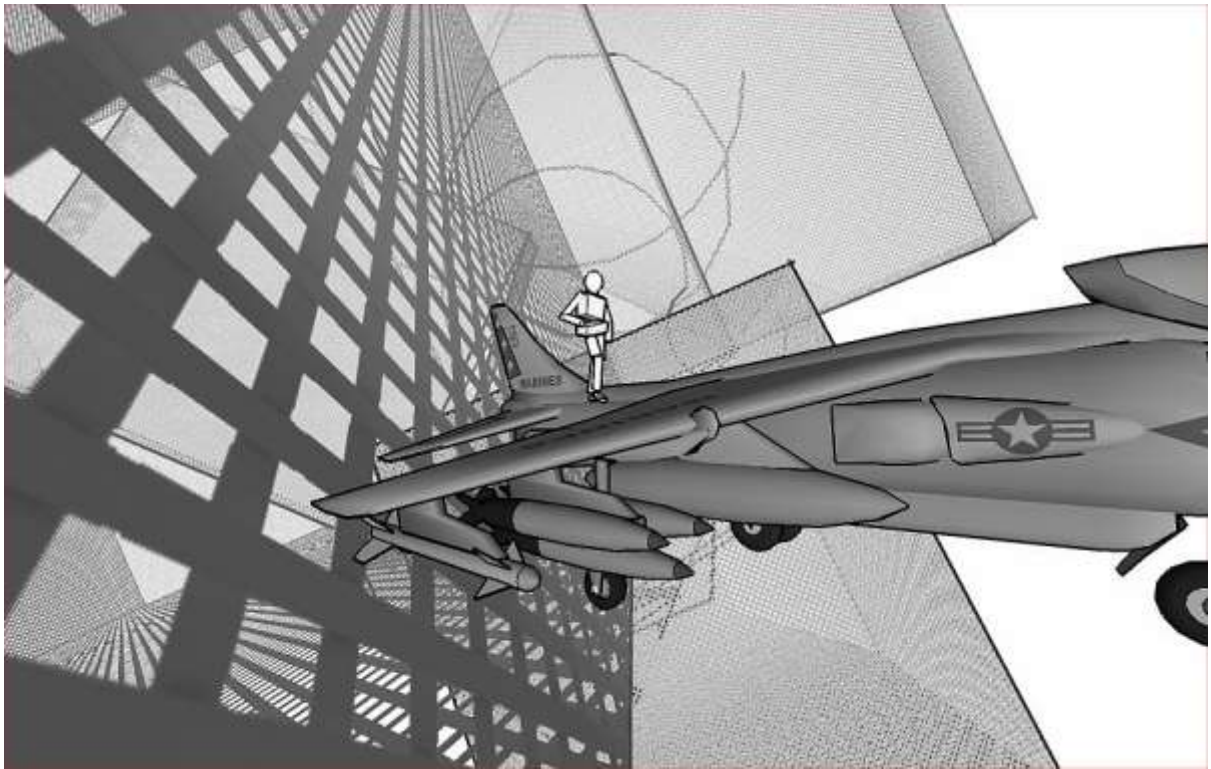
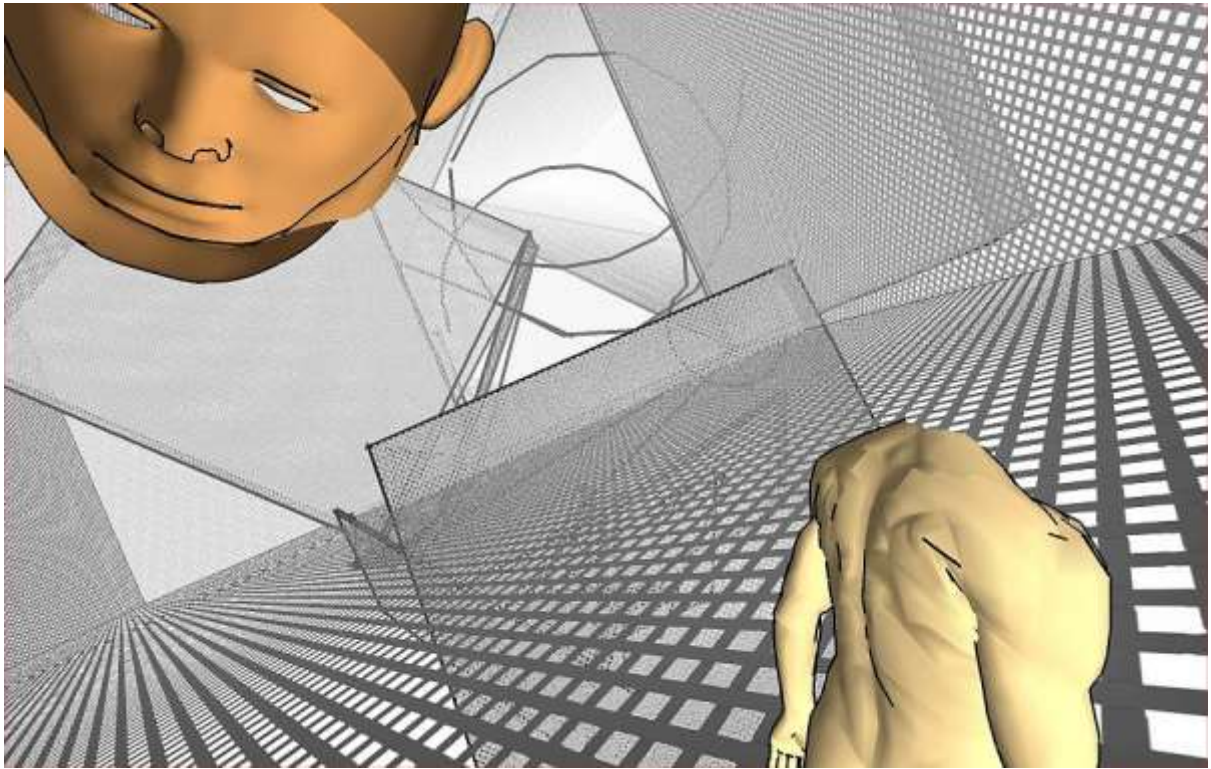

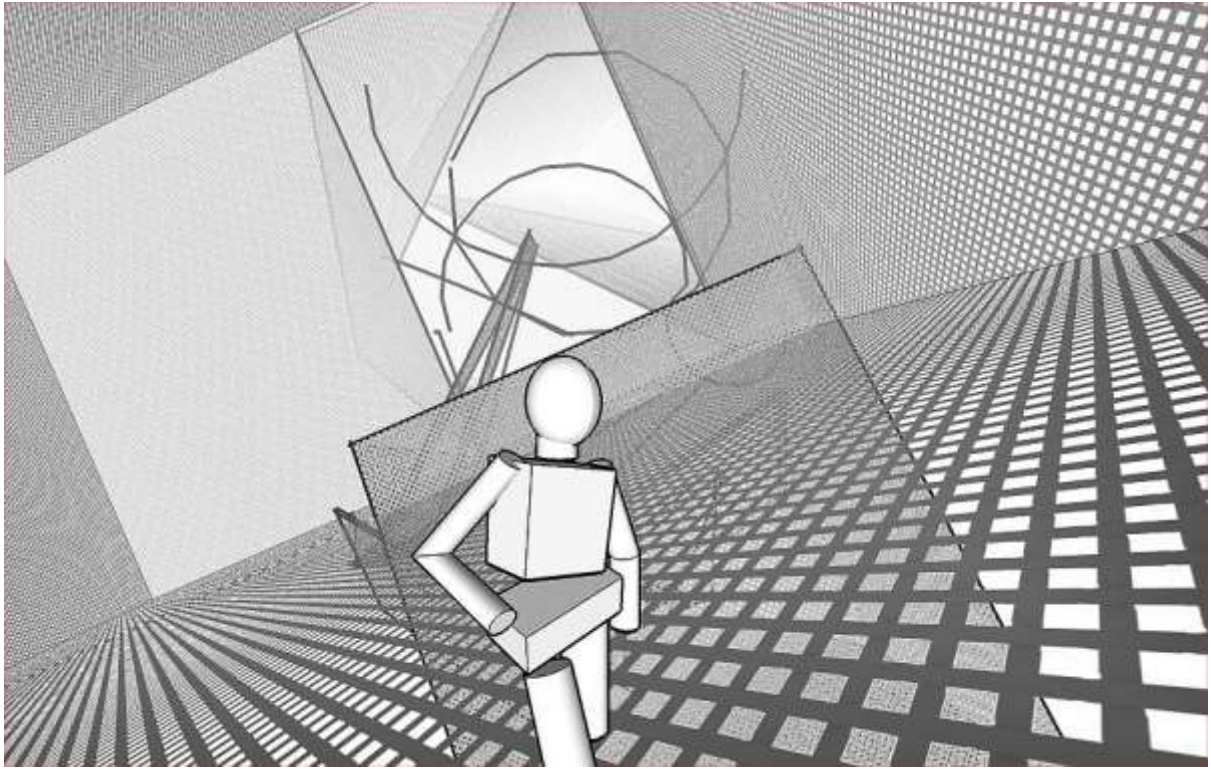
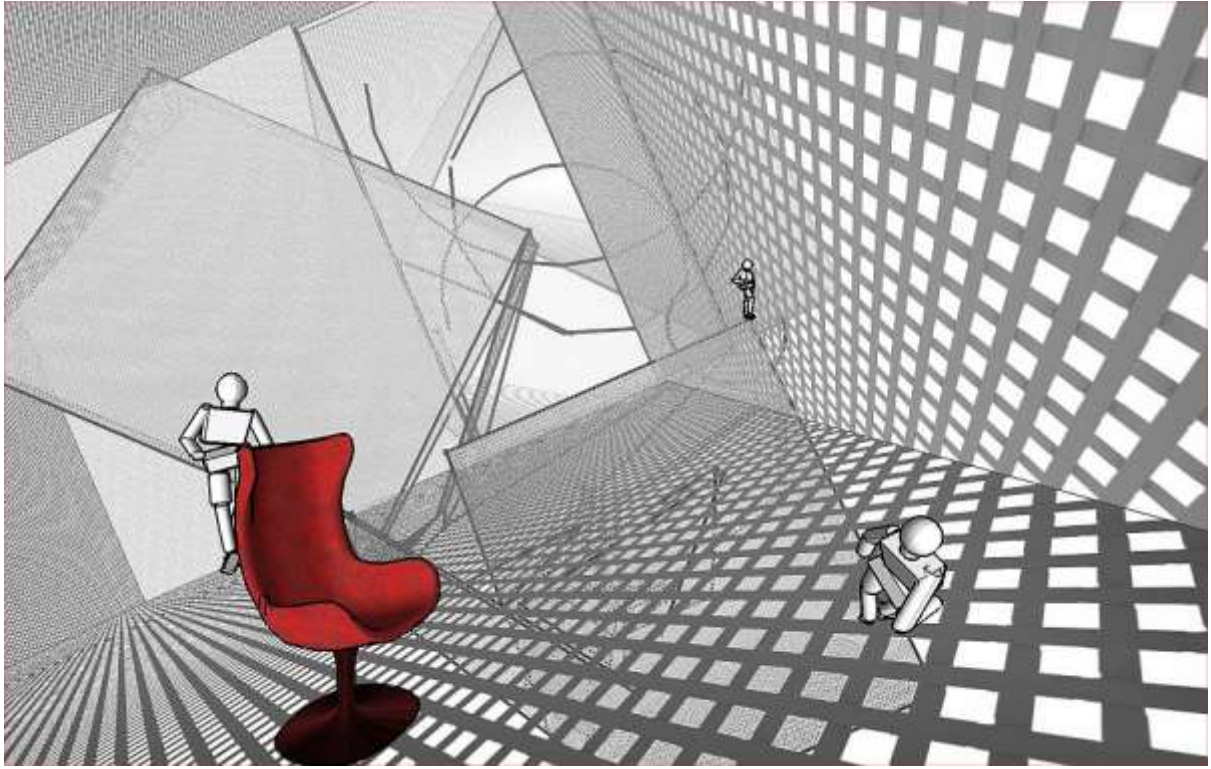

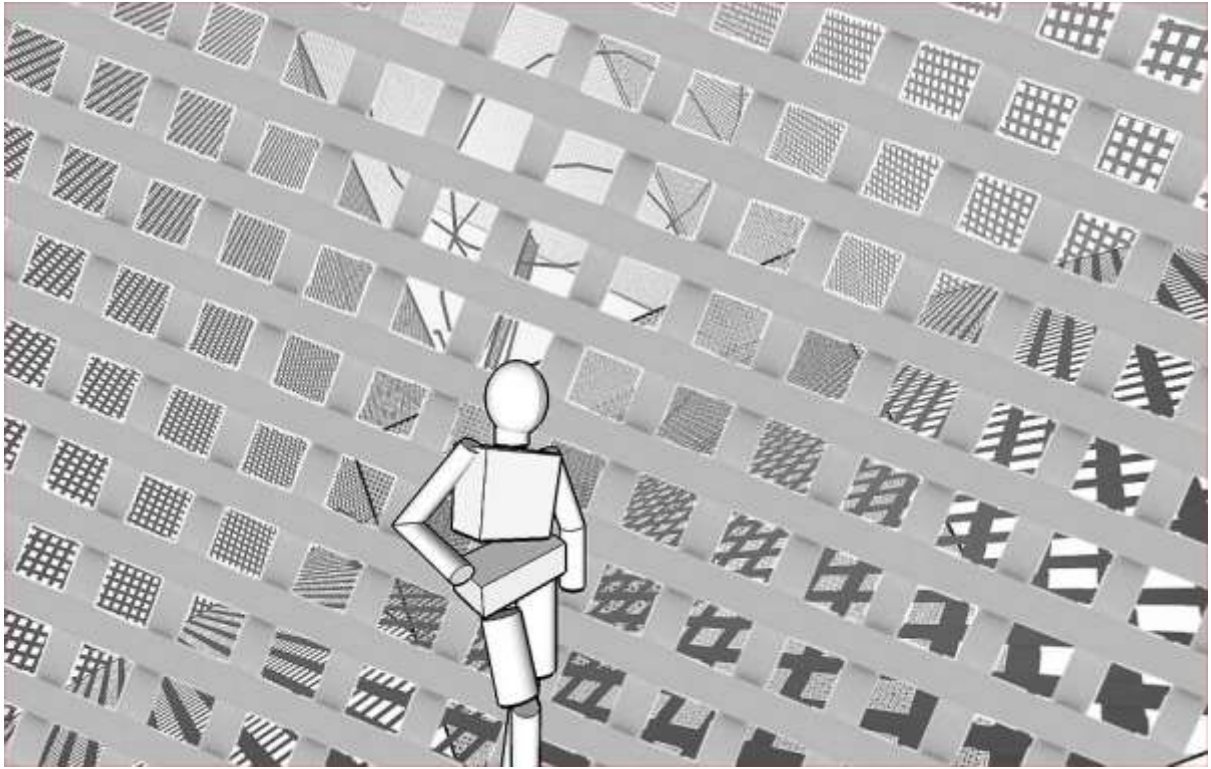
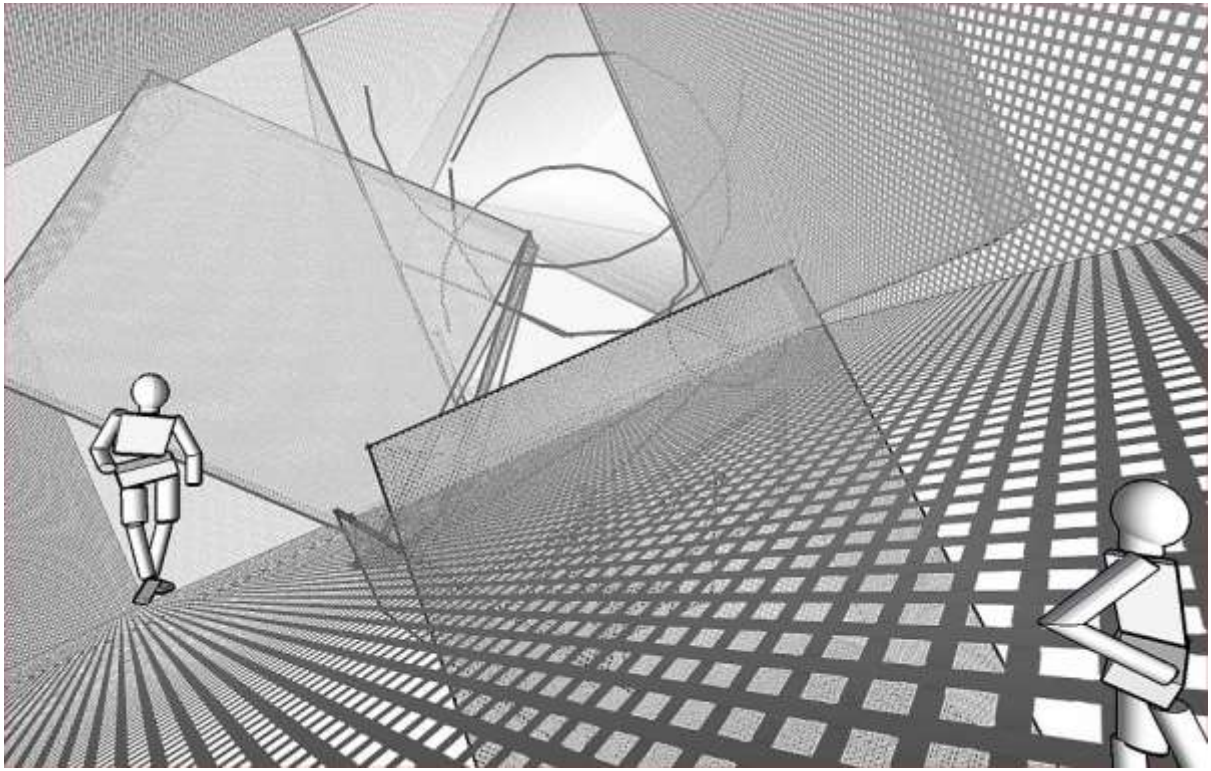

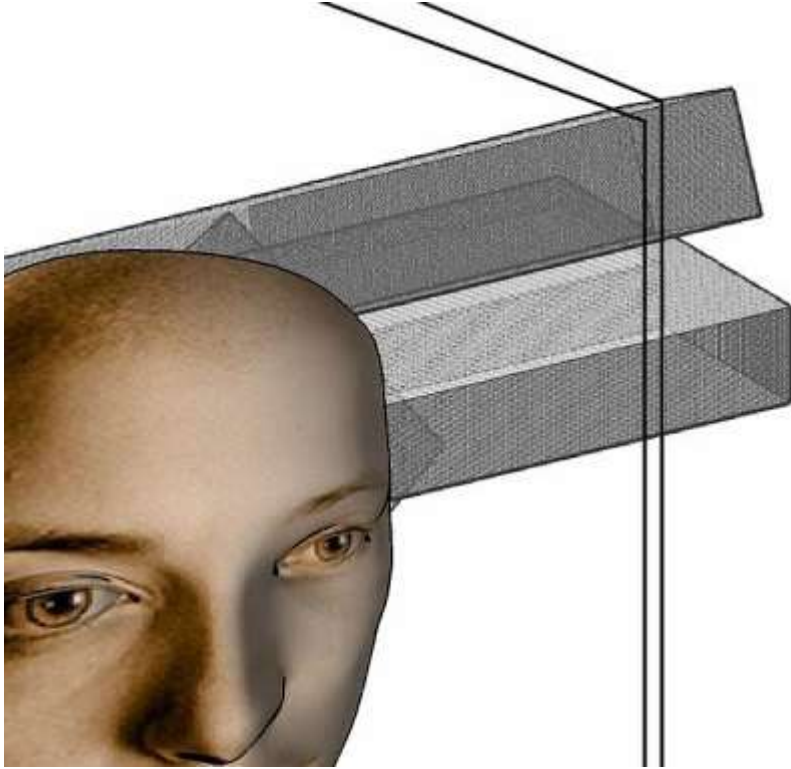
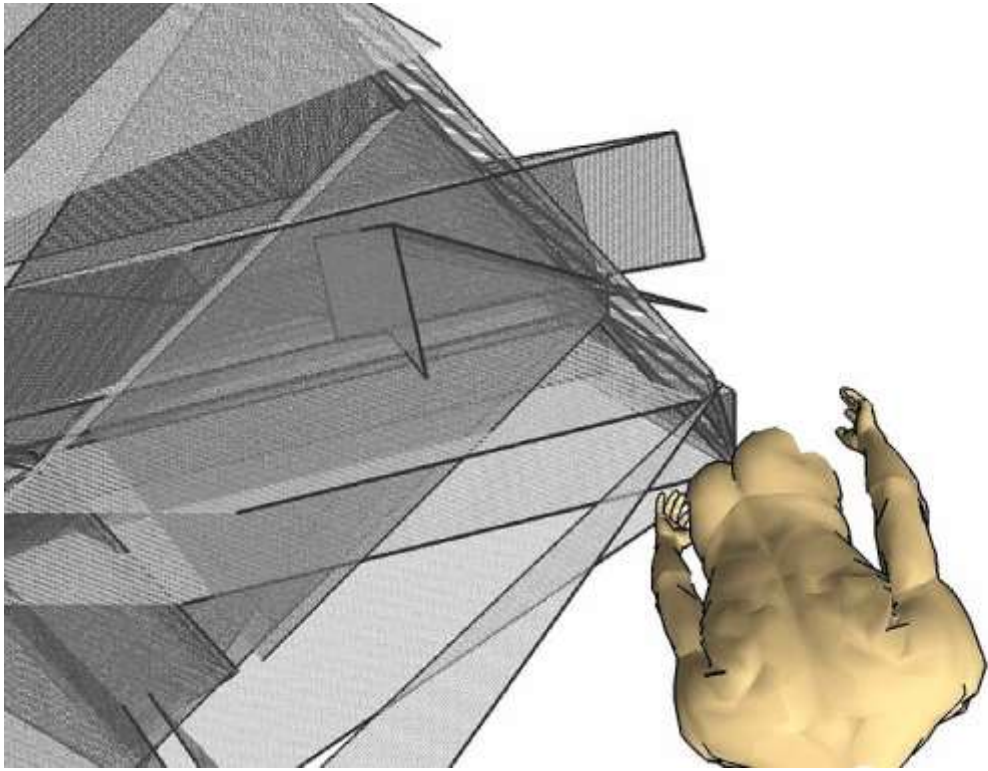

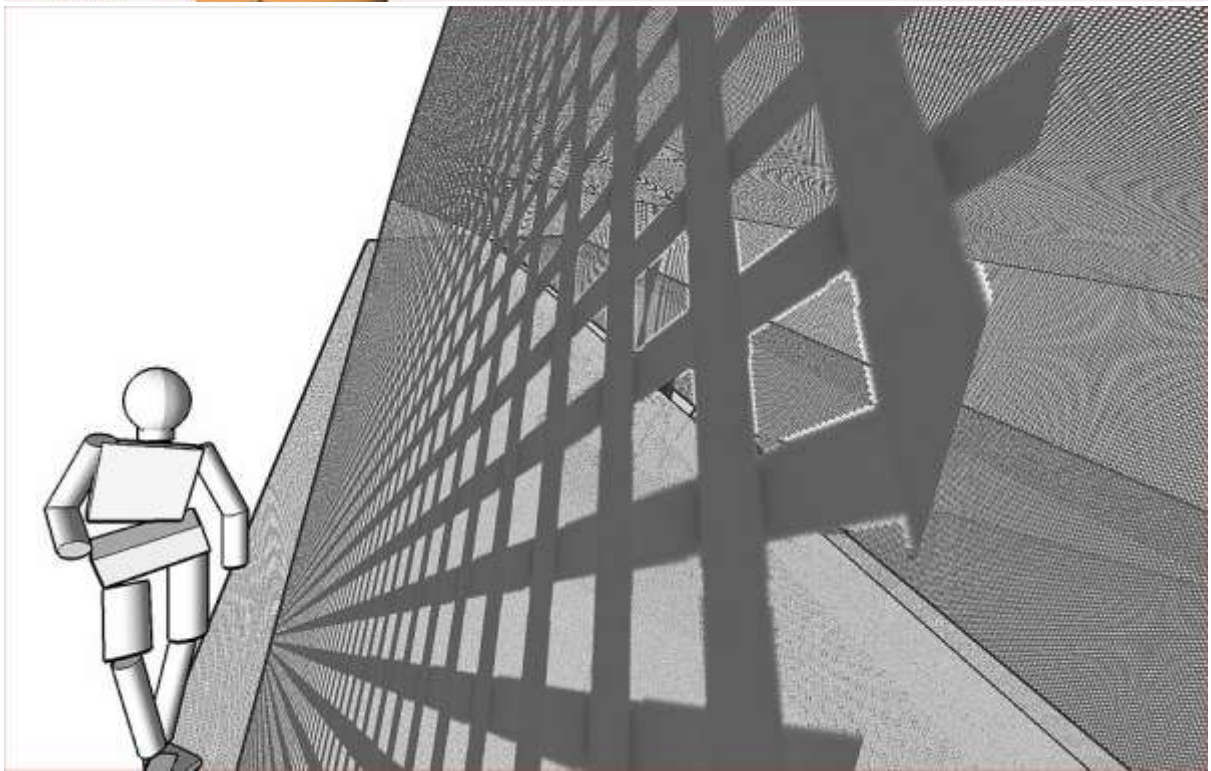
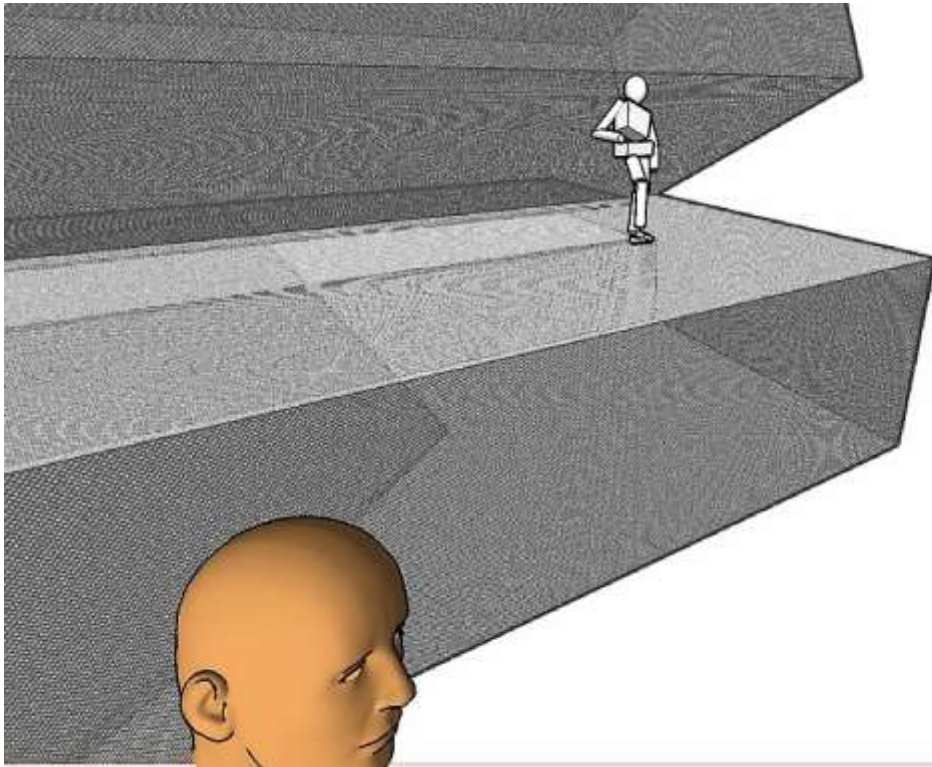

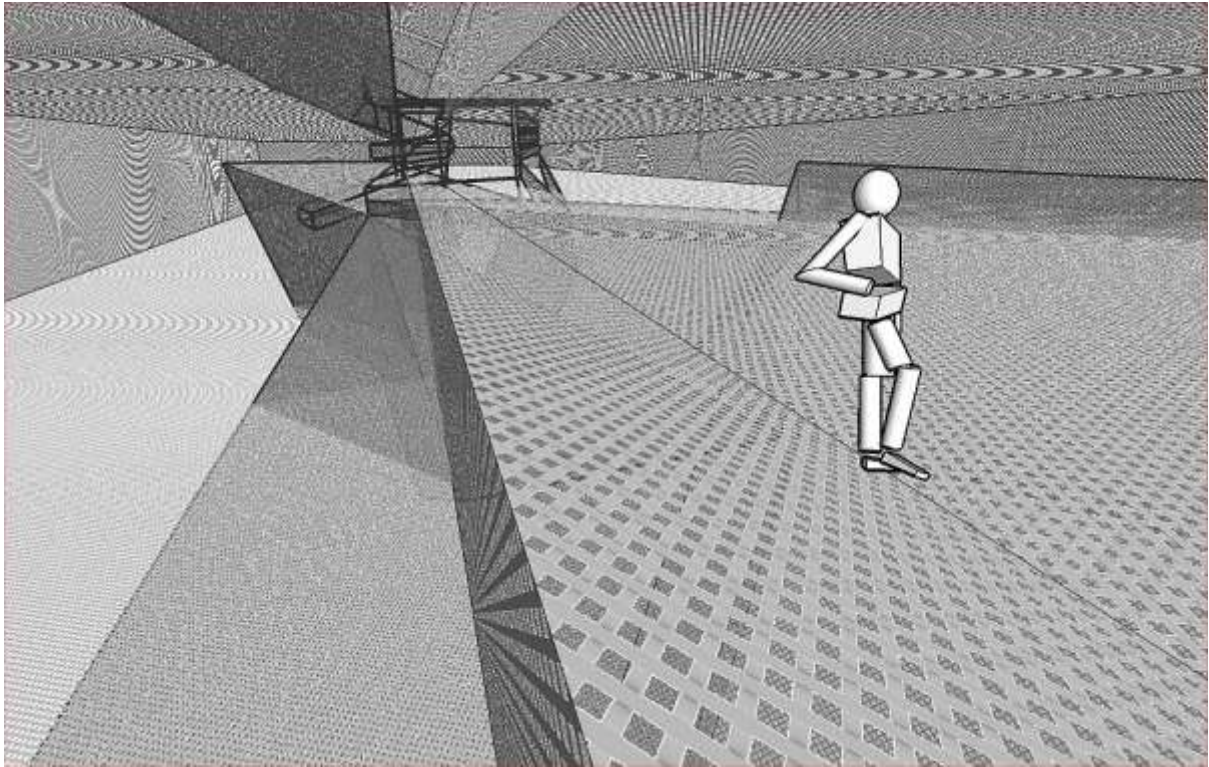
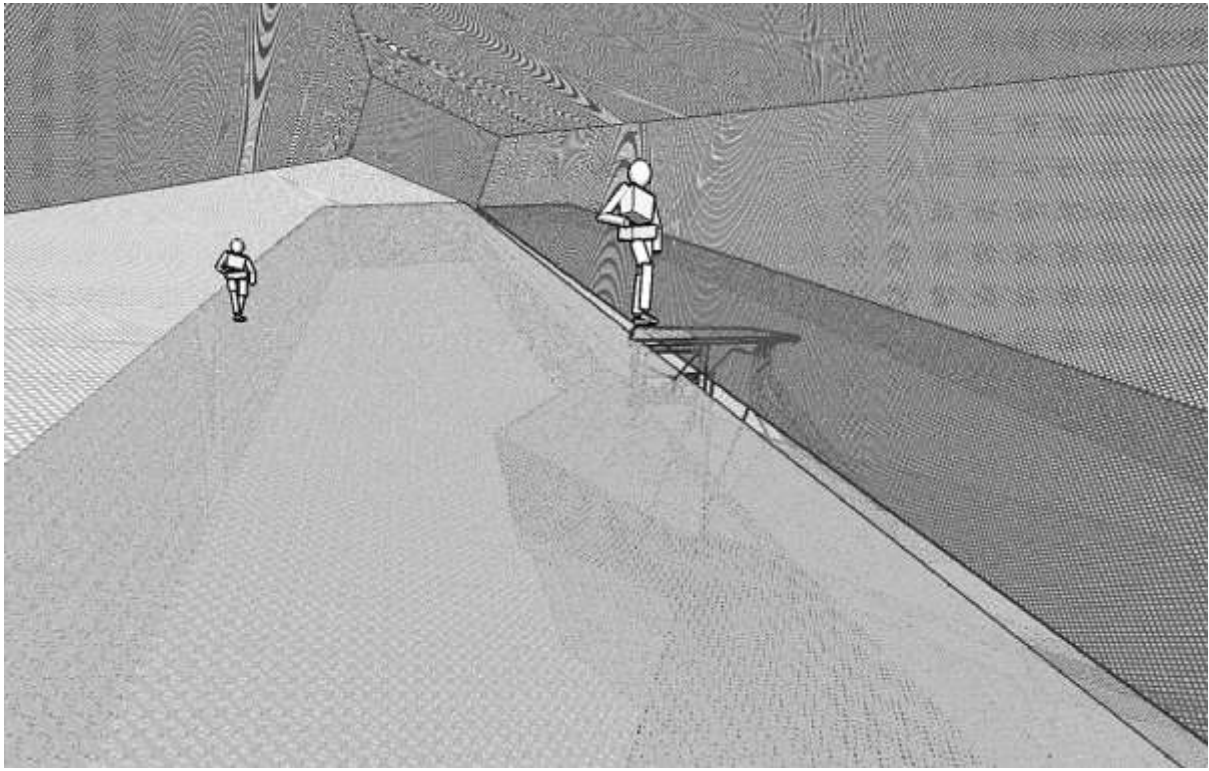

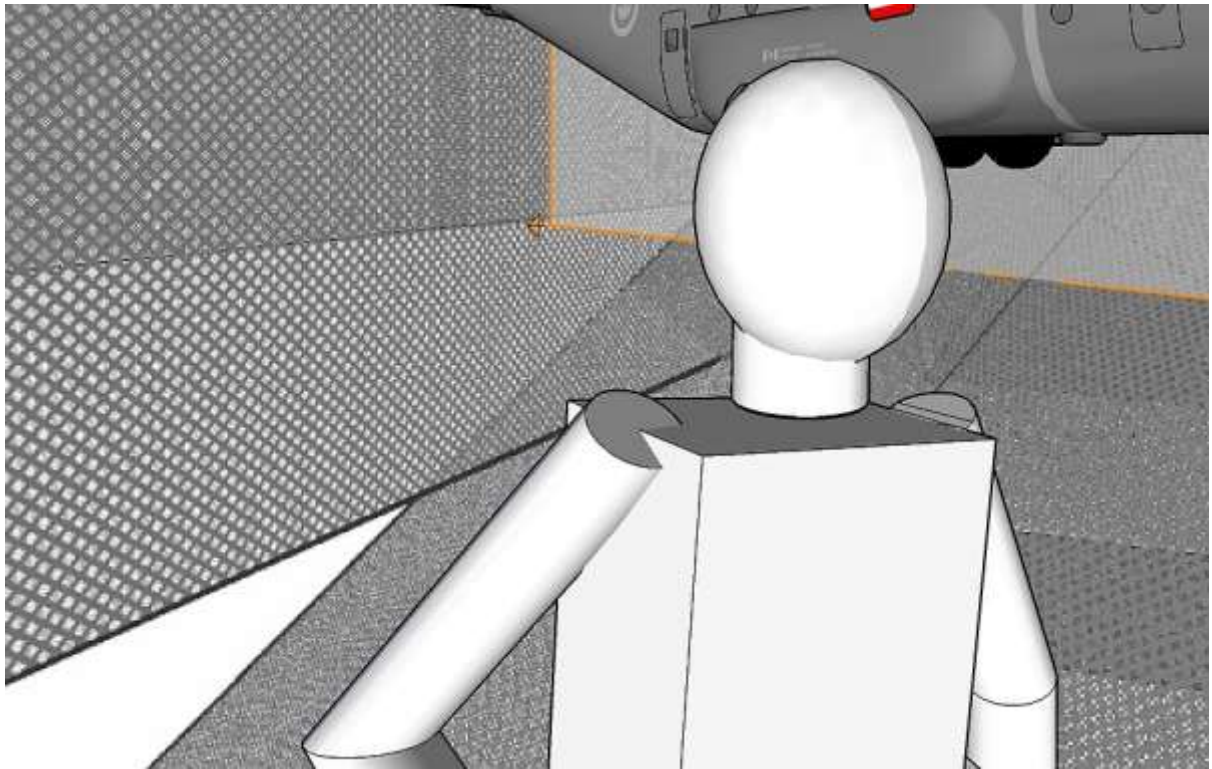
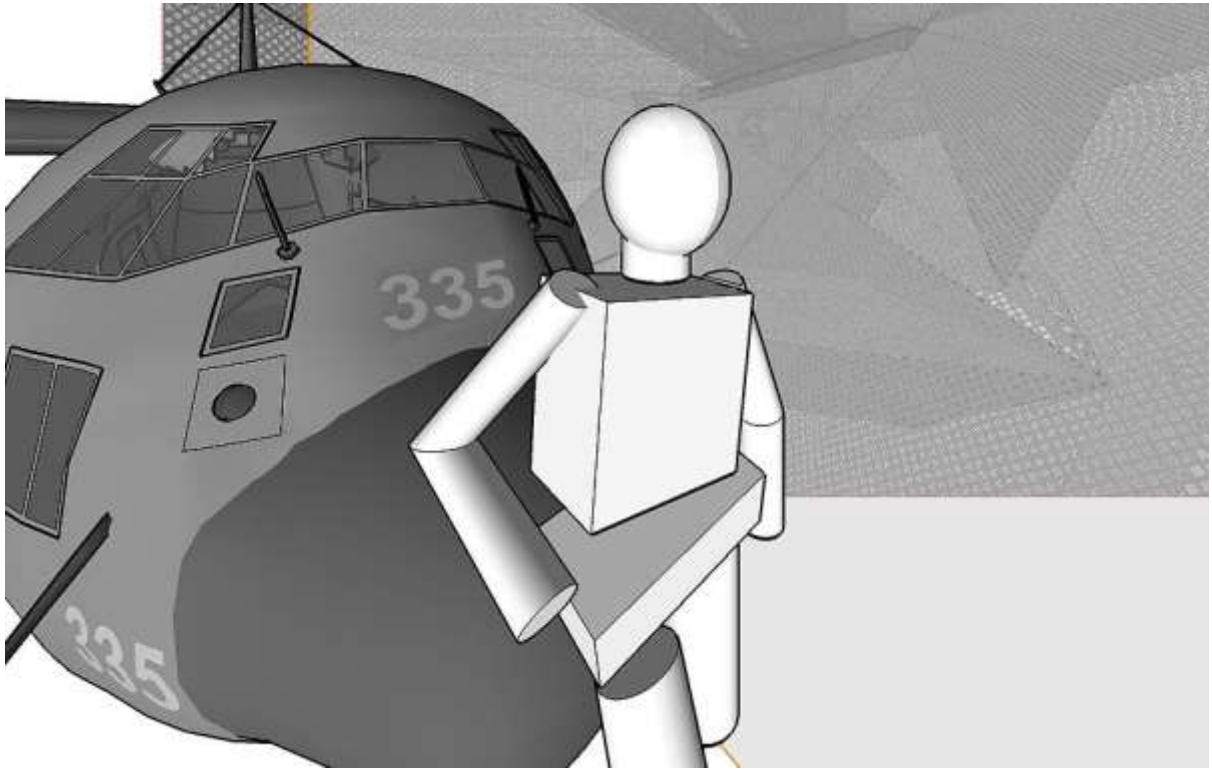

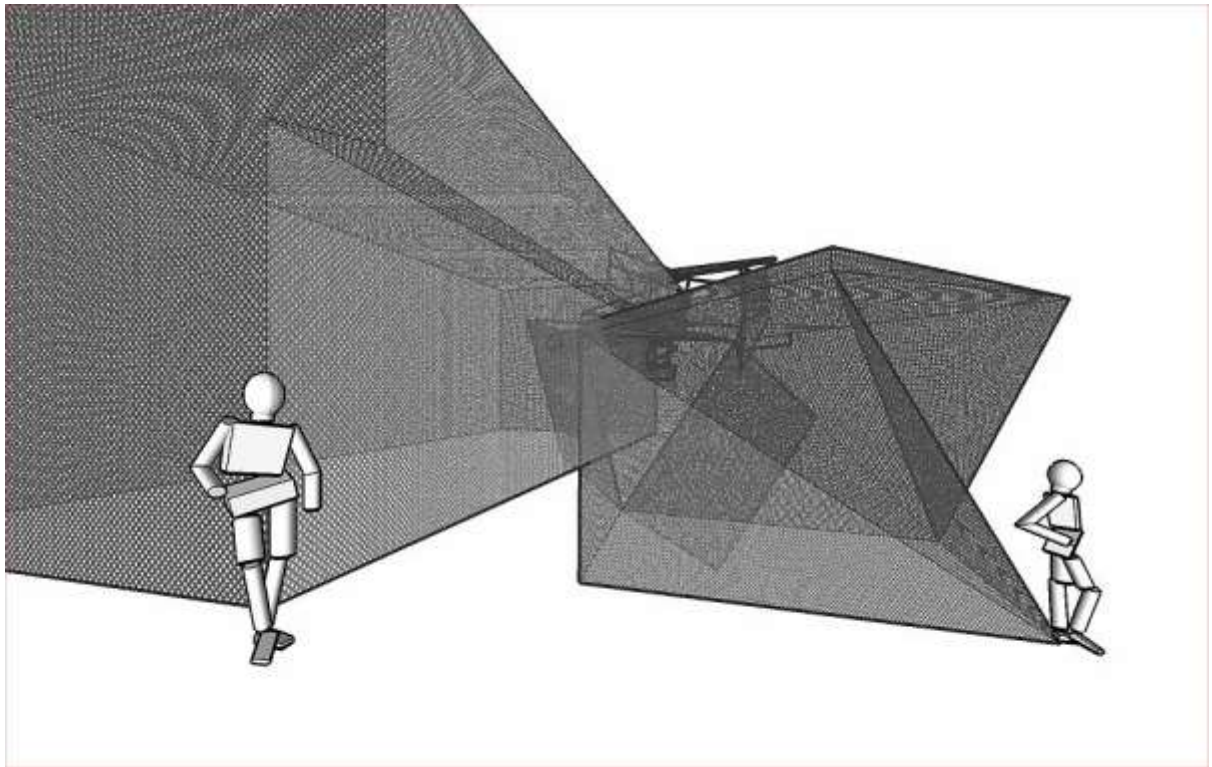
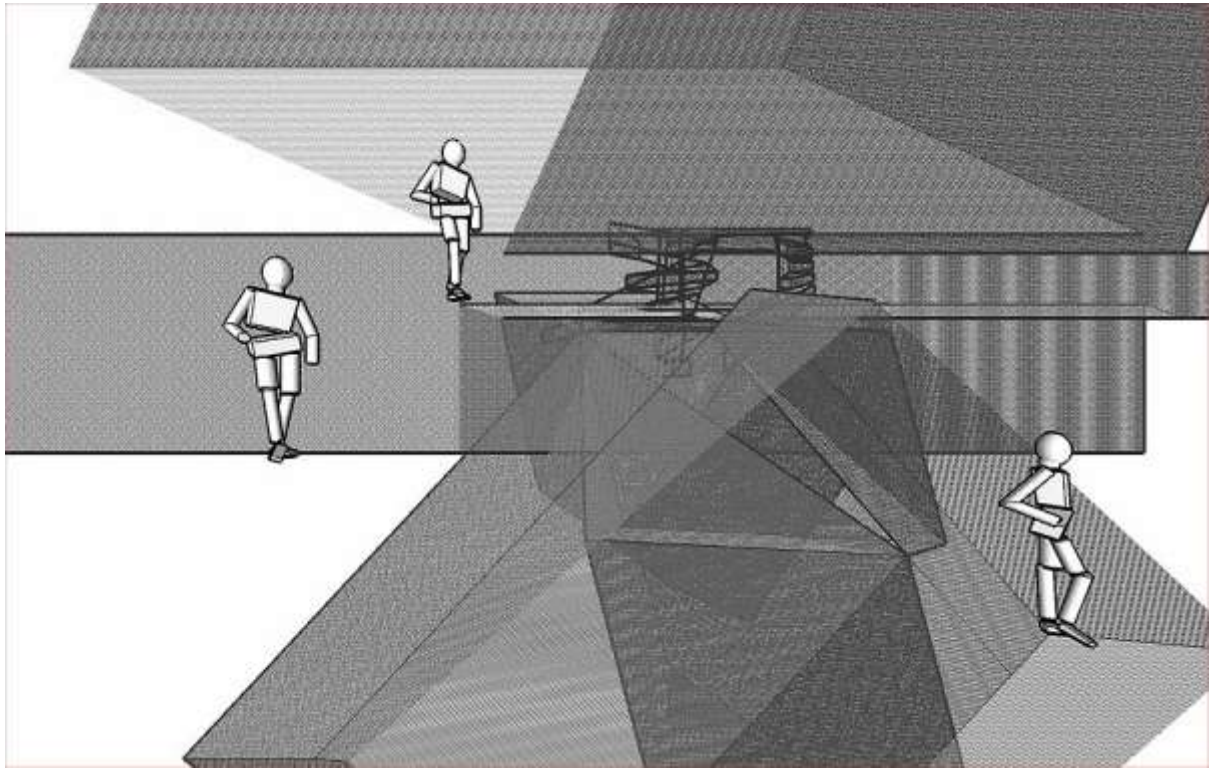

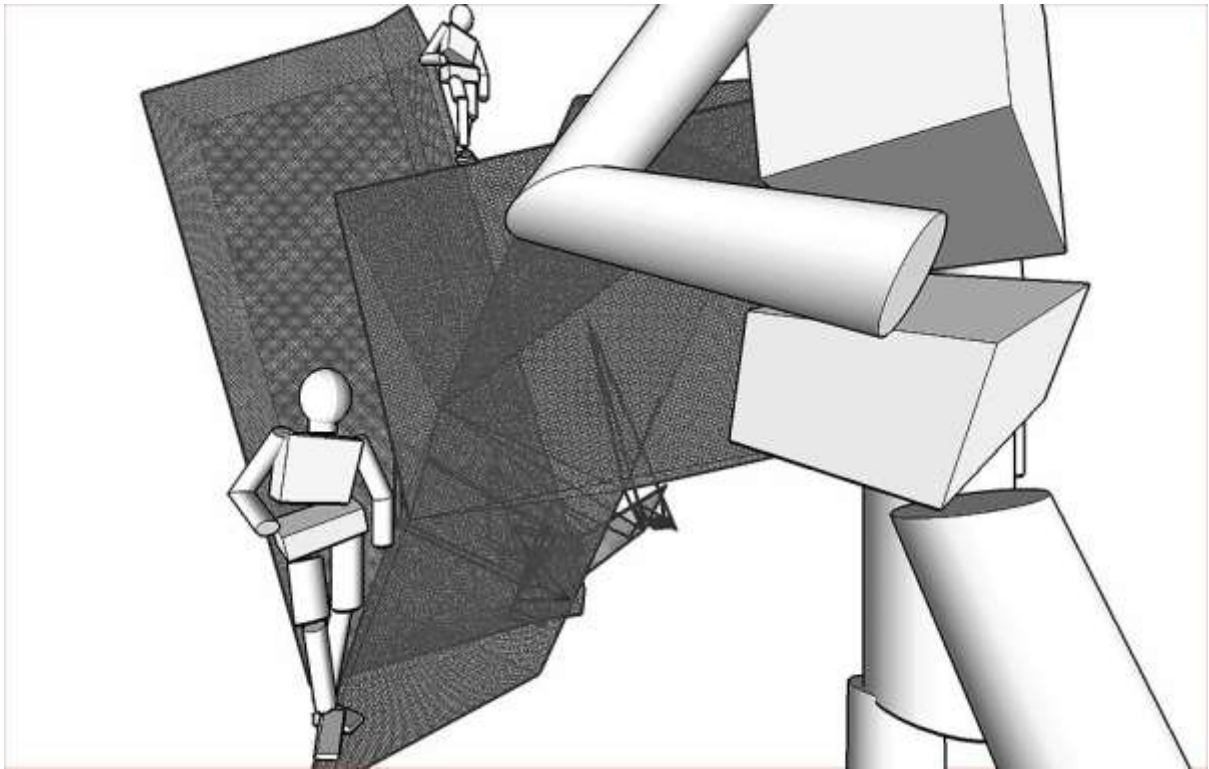
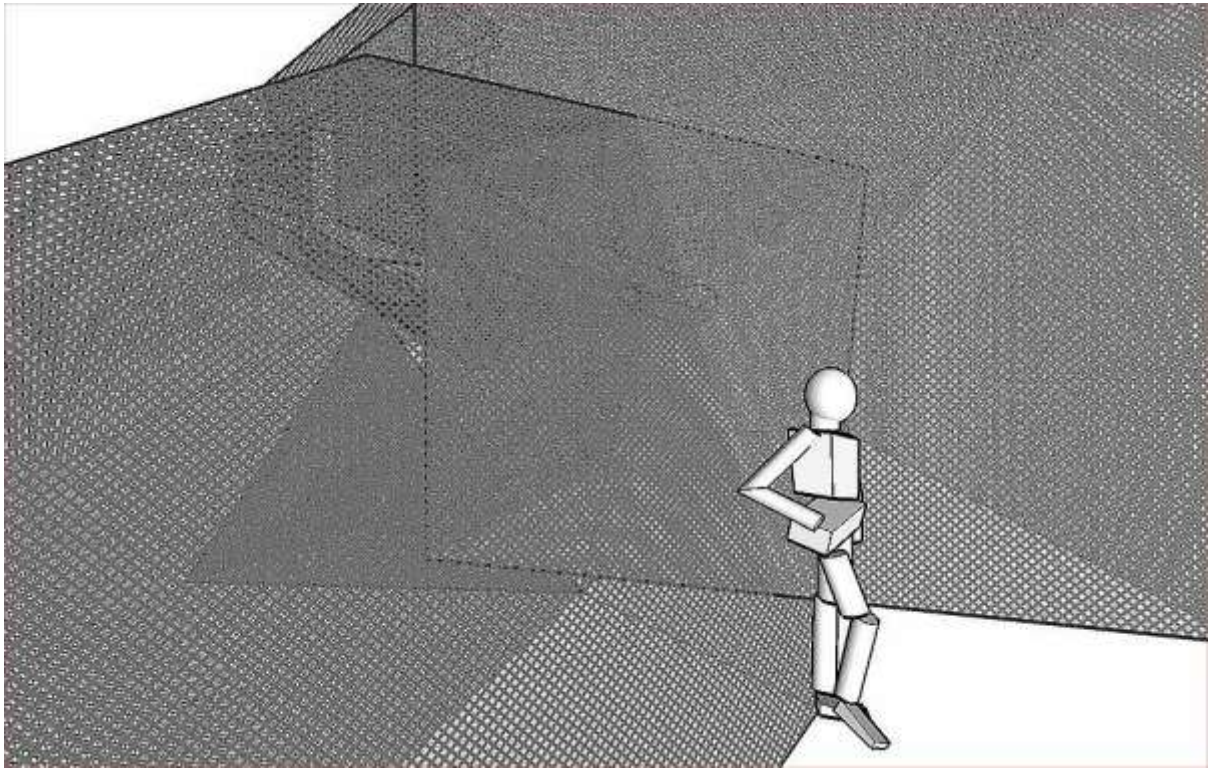

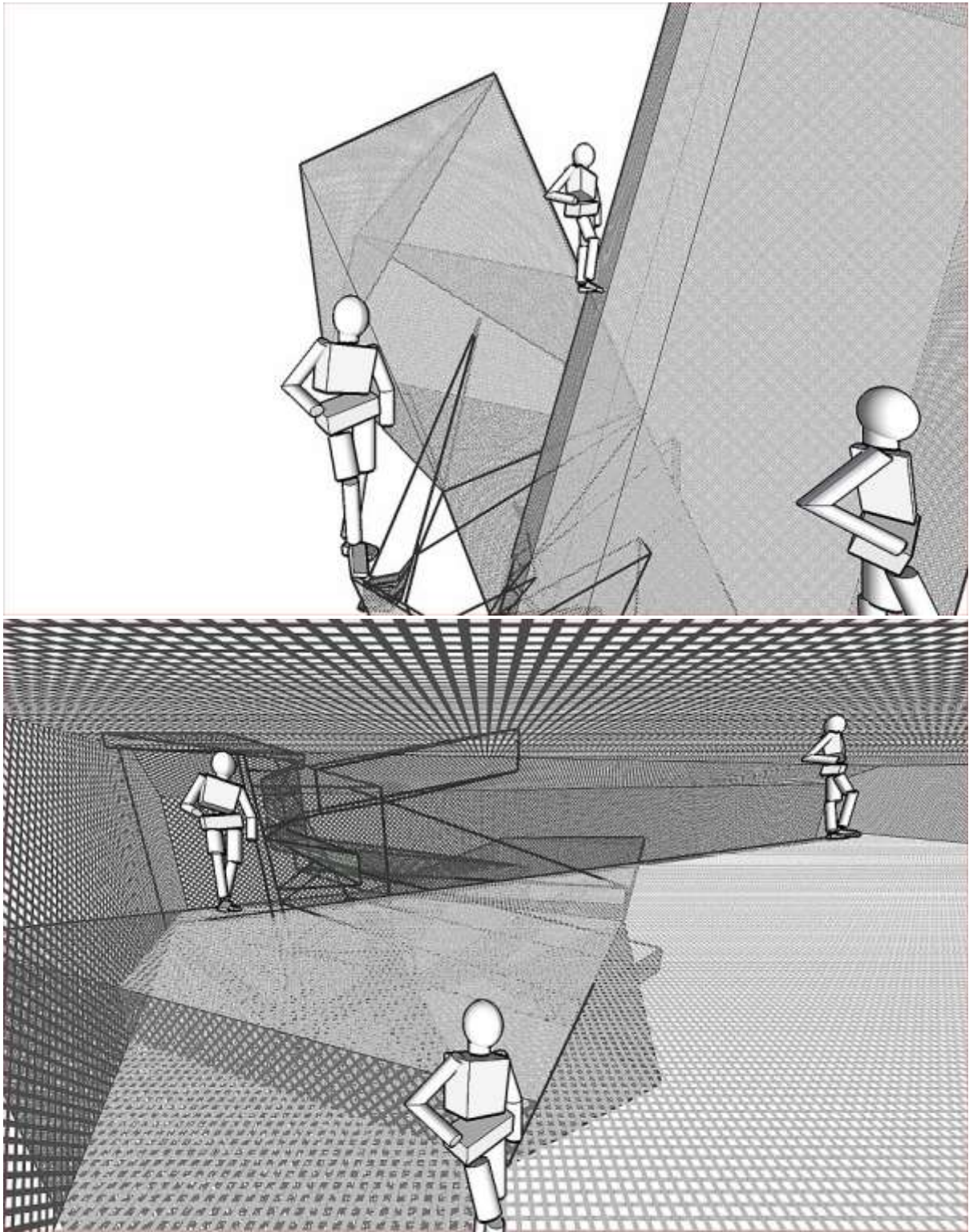

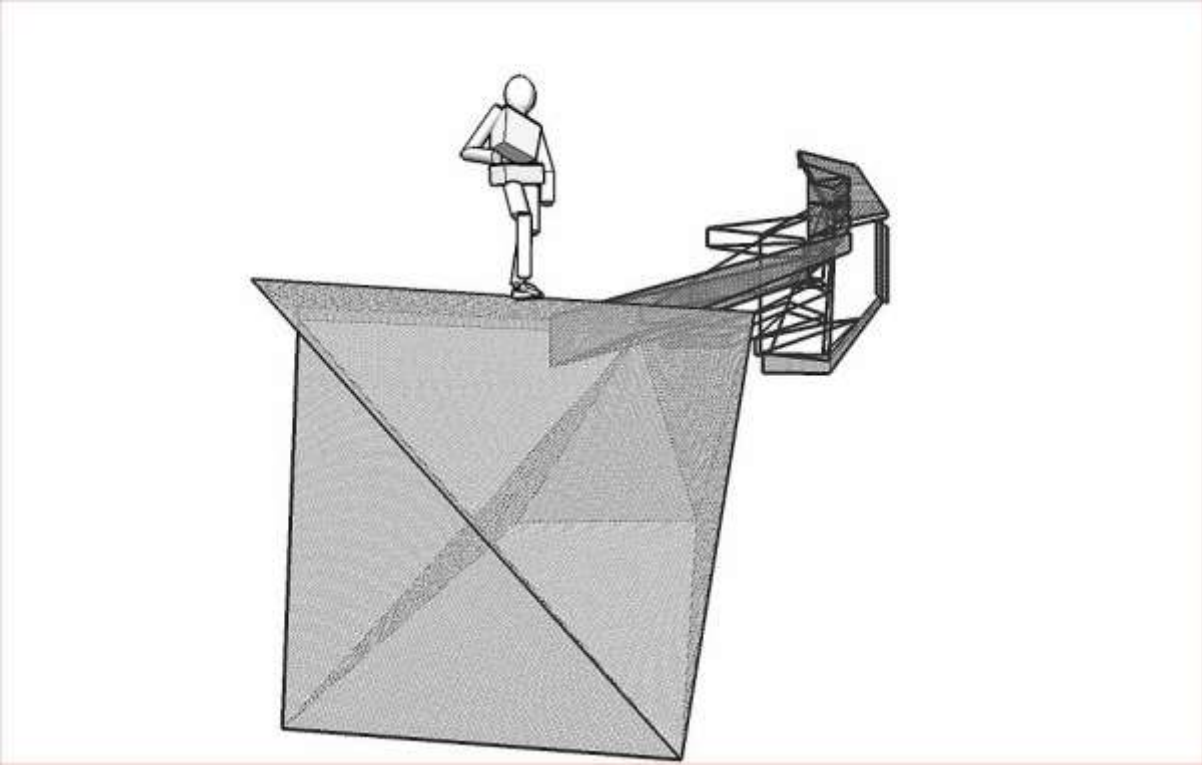
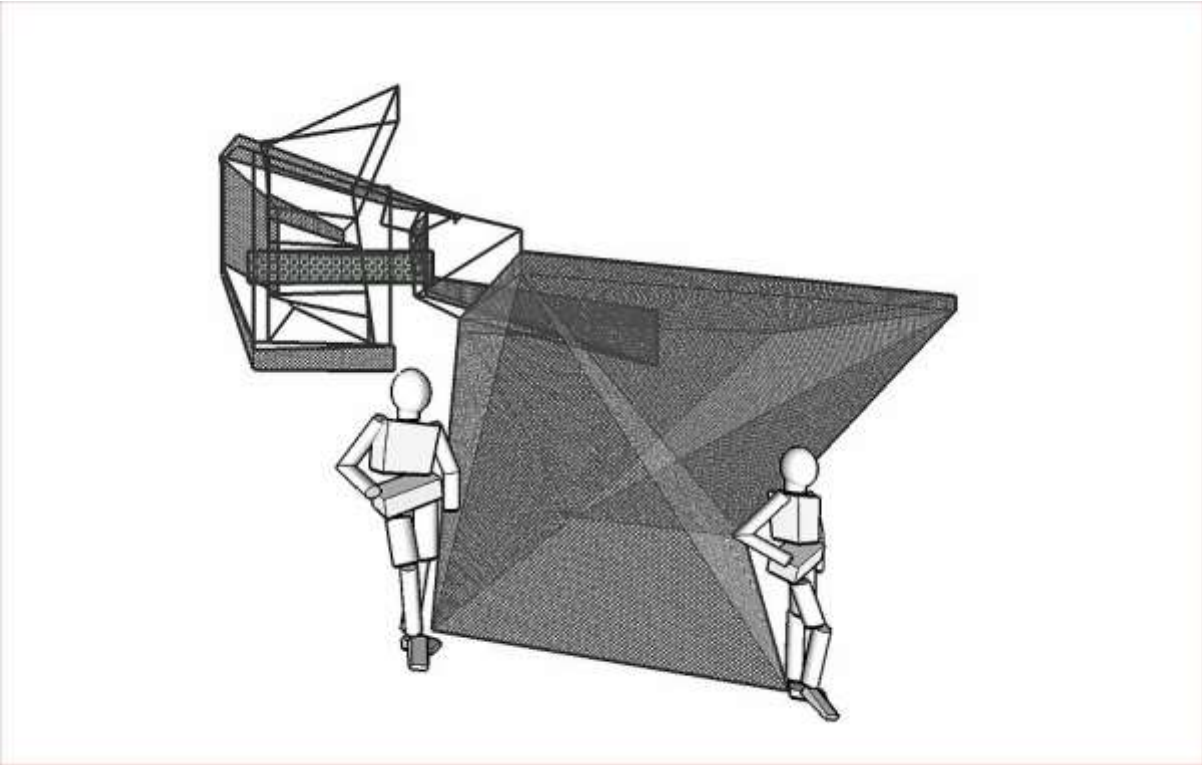

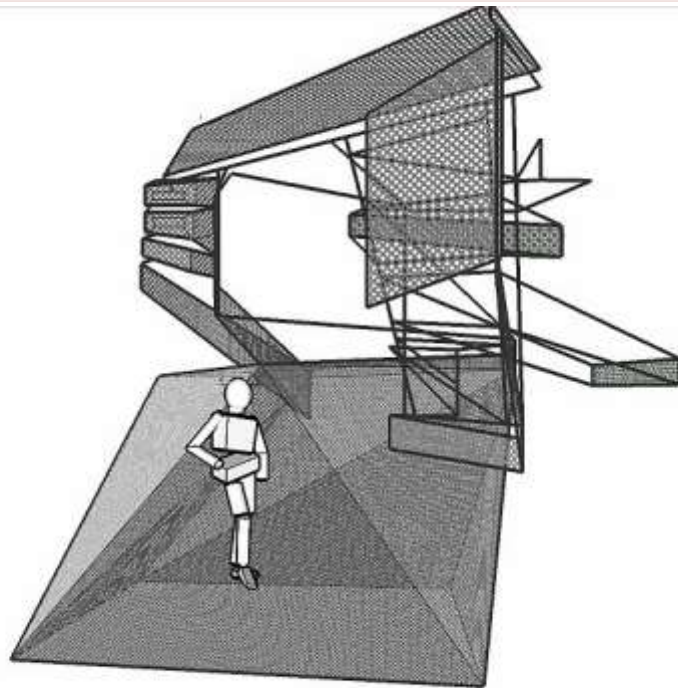
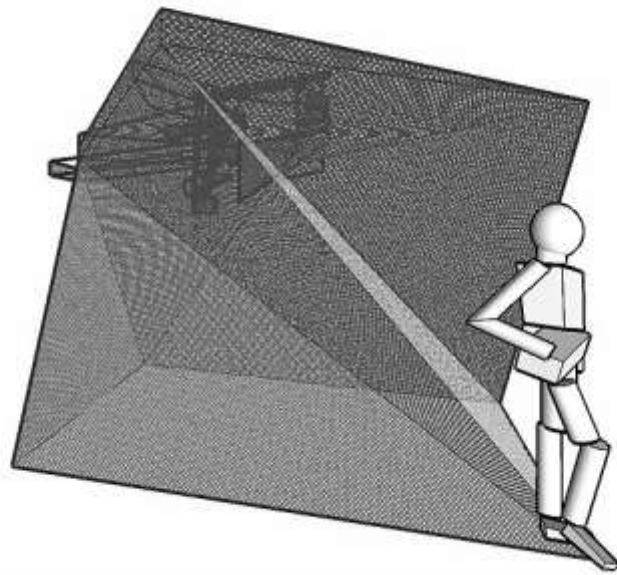

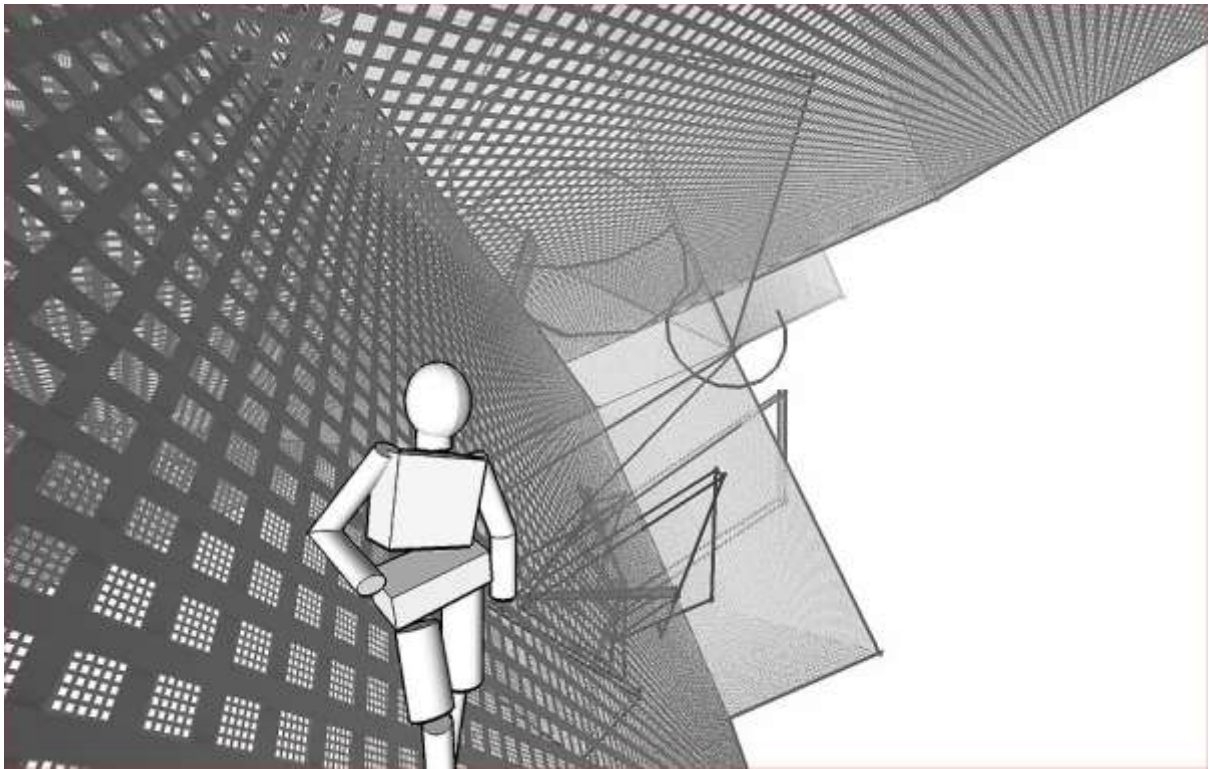
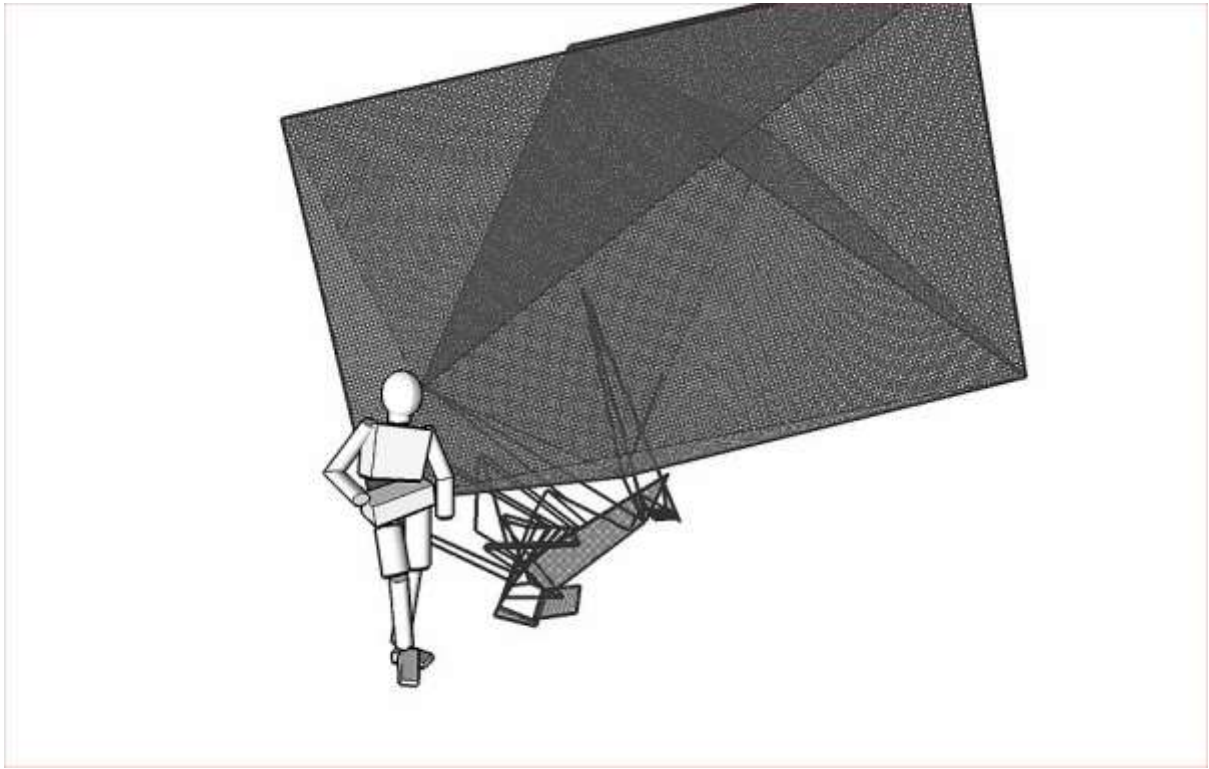

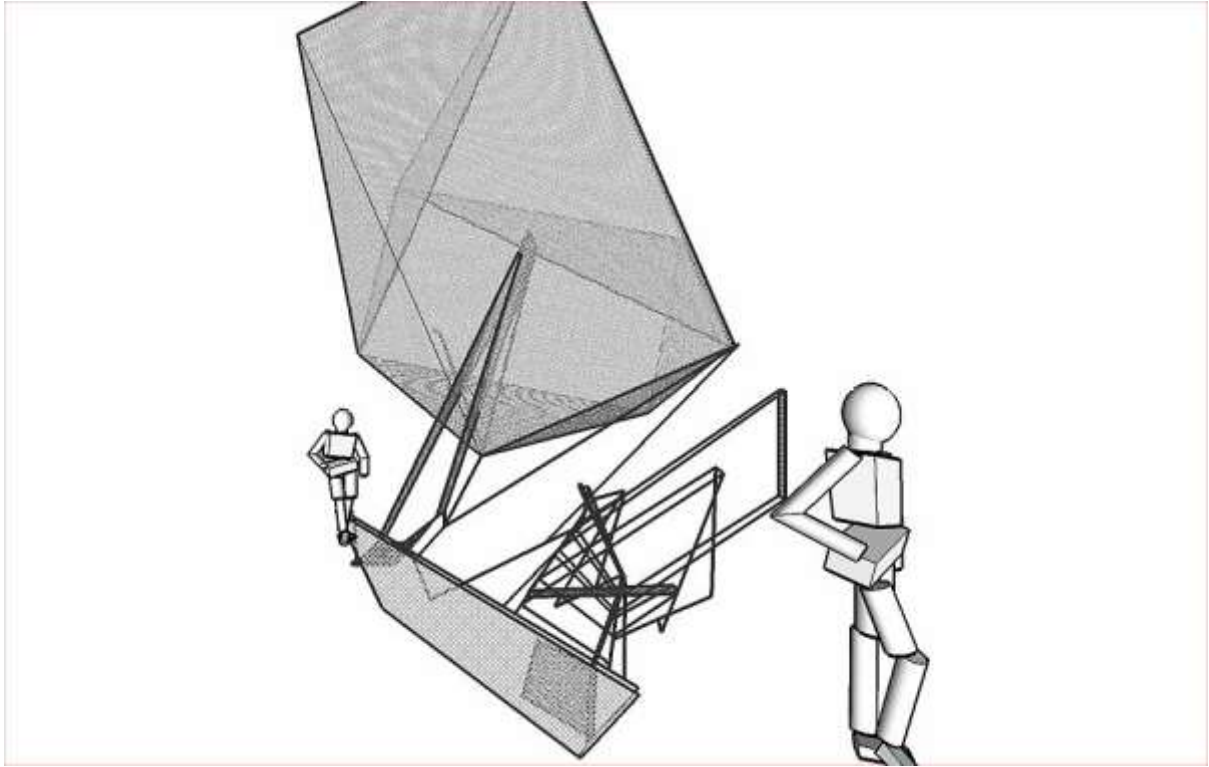

## **Internet Sources**

### **Theater Comics: Utopian Set Designs: In Search Of Lost Director (July 2020)**

[https://www.facebook.com/pg/MacedonianCenterofInternationalTheaterInstitute/photos/?tab=album&album\\_id=4112748568767857](https://www.facebook.com/pg/MacedonianCenterofInternationalTheaterInstitute/photos/?tab=album&album_id=4112748568767857)

### **DIGITAL EXHIBITION (Theater Comics): In Search of Lost Director (Utopian Set Designs) (July 2020)**

[https://www.youtube.com/watch?v=56jPKW8w0H8&fbclid=IwAR1FA\\_3kc9FLgVTVFq6b1GR95QUAe8uGAv9QLJFtgWEvRwiSofNHKf6csXM](https://www.youtube.com/watch?v=56jPKW8w0H8&fbclid=IwAR1FA_3kc9FLgVTVFq6b1GR95QUAe8uGAv9QLJFtgWEvRwiSofNHKf6csXM)

### **Theater Comics: Utopian Set Designs: In Search Of Lost Director (July 2020)**

<https://www.facebook.com/events/664585387426441/>

### **Solo Expo: In Search of Lost Director, Macedonian Cinemateque, Skopje, 2011 (July 2020)**

[https://www.facebook.com/pg/ProdukcijaMacedonianCenterITI/photos/?tab=album&album\\_id=811331058899929](https://www.facebook.com/pg/ProdukcijaMacedonianCenterITI/photos/?tab=album&album_id=811331058899929)

### **Solo Expo: In Search of Lost Director, Macedonian Cinemateque, Skopje, 2011 (July 2020)**

[https://www.facebook.com/apostolova.ivanka/media\\_set?set=a.1653631954876&type=3](https://www.facebook.com/apostolova.ivanka/media_set?set=a.1653631954876&type=3)

### **Solo Expo: Iskanje izgubljenega režiserja, Theater Museum Ljubljana, 2009 (July 2020)**

[https://www.facebook.com/apostolova.ivanka/media\\_set?set=a.1141513312230&type=3](https://www.facebook.com/apostolova.ivanka/media_set?set=a.1141513312230&type=3)

## **THEATROGRAPHY**

Theater projects (2020-2004):

### **2020/2013**

Program / Projects design, Macedonian Center of International Theater Institute, Skopje.

<https://www.facebook.com/pages/ITI-Macedonian-Center-of-International-Theatre-Institute/697139220328826>

<http://www.iti-worldwide.org/macedonia.php>

<https://www.facebook.com/pg/MacedonianCenterofInternationalTheaterInstitute/photos/?tab=albums>

### **2018**

Theater performance: Pettiot cin, (visual dramaturgy-play translation, set/costume/light/video/ expo design), directed by Niko Gorsic, National Theater Anton Panov – Strumica, Ministry of culture, R. Macedonia. (Premiere: 5 September 2018). <https://www.facebook.com/pg/MacedonianCenterofInternationalTheaterInstitute/phot>

os/?tab=album&album\_id=2178785612164172

## **2012**

Gledališče senc, performans, neposredna komunikacija: kulturna socijalizacija ranjivih, Illustrations, organizers: Serbian Cultural Centre Danilo Kis, Ljubljana, Slovenia with Dr. Svetlana

Slapsak, [http://www.dkis.si/index.php?option=com\\_content&view=category&layout=blog&id=57&Itemid=270&lang=sl](http://www.dkis.si/index.php?option=com_content&view=category&layout=blog&id=57&Itemid=270&lang=sl)

<http://www.gledalisce-senc.si/o-projektu/o-nas>

## **2011**

(July) Intersected Witches, Mentor, theatre Comics Workshop for students, collage and mixed media, organizers: Scenofest, OISTAT, DAMU, Prague Quadrennial of Performance Design and Space, Prague, Czech Republik. <http://scenofest.pq.cz/workshops/selected-workshops/other-comics-fashion-opera-text-etc/>, [https://www.facebook.com/apostolova.ivanka/media\\_set?set=a.1731174253385&type=3](https://www.facebook.com/apostolova.ivanka/media_set?set=a.1731174253385&type=3)

(June) Group exhibition, Who`s Afraid of Religious Plecnik?/Kdo se boji religioznega Plecnika?, Set/Costume designers: Petra Veber, Vasilija Fiser, Belinda Radulovic, Mateja Benedetti, Slovenian Theatre Museum, Ljubljana, Slovenia. Donator: Ministry of Culture of R. Slovenia. [https://www.facebook.com/apostolova.ivanka/media\\_set?set=a.1704669270777&type=3](https://www.facebook.com/apostolova.ivanka/media_set?set=a.1704669270777&type=3)

**2009** – (September/November) Set /Costume/Graphic Design, project: 2 Brothers, directed by Alen Jelen, Shkuc Gledalisce/Theatre, Gledalisce/Theatre Glej, Ljubljana, Slovenia. <http://www.glej.si/2009/11/brata/>; <http://www.skuc.si/index.php?id=100>, [https://www.facebook.com/apostolova.ivanka/media\\_set?set=a.1144104617011&type=3](https://www.facebook.com/apostolova.ivanka/media_set?set=a.1144104617011&type=3)

**2009/2008** – (January/October) Assistant Set Designer (Set design: Mr. Branko Hojnik), project: Oresteia, directed by: Jernej Lorenci, Slovenian National Drama Theatre, Ljubljana, Slovenia. <http://www.drama.si/repertoar/oresteja.html>

**2008** - (April, March) Costume design, project: Mojot svet/My World, written by: Bedia Begovska, director: Viktorija Rangelova, Turkish Drama Theatre, Skopje, Macedonia.

**2007** – (April/February) Theater video art, project: Ljubezen na smrt/Love Unto Death, directed by: Matjaž Pograjc, Slovenian Mladinsko Theater, Slovenia. (Including lecturing for the team of actors and actresses of the same performance, subject: Theory of Provocation in the films of Rainer Werner Fassbinder). [www.mladinsko.com/predstave?show\\_id=241](http://www.mladinsko.com/predstave?show_id=241)  
[www.silence/zone.com/disco\\_love.htm](http://www.silence/zone.com/disco_love.htm)

**2007/2006** - (April/November) Theater design for puppets, costumes, scenography, project: Deklica z violino/Girl with Violin, directed by: Boris Kobal, Puppetry Theater Ljubljana, Slovenia. [www.lgl.si/predstave/dviolina.swf](http://www.lgl.si/predstave/dviolina.swf)

**2005/2004** – Research/Portfolio: Fictive Theatre Repertoire by Ivanka Apostolova, Ljubljana, Slovenia. [www.agrft.uni-lj.si/e-kumba/](http://www.agrft.uni-lj.si/e-kumba/)

**2004** - (December/October) Scenography and costumography assistant, author of promotional theater comic, theater project: Bolje tič v roki kot tat na strehi-absurd comedy, director: Matjaž Zupančič. Mentor and scenographer/costumographer: Janja Korun, Mestno gledališče ljubljansko, Slovenia. [www.mgl.si/pOutic.html](http://www.mgl.si/pOutic.html)

## **1992/1989**

Performing (directing, acting, singing), Theater Studio Crv/Worm and Kerubini, Skopje, Macedonia. (Collaboration with: Aleksandar Popovski – Theater director, Darko Mitrevski – Film and TV

director). [https://www.facebook.com/apostolova.ivanka/media\\_set?set=a.10206040478845234&type=3](https://www.facebook.com/apostolova.ivanka/media_set?set=a.10206040478845234&type=3)

## **COMICOGRAPHY**

### **Graphic novel (Editor):**

*Personal futurism / Public politics*, Editor: Ivanka Apostolova, PRODUKCIJA Press, Skopje, 2013 (Artists: Zograf-Sasa Rakezic, Vladimir Palibrk, So Soniaqq, Neza Zinajic, Martina Lajtner, Ivana Armanini, Filip Andronik, Damir Steinfl, Franco Sacchetti, Gorand-Goran Dacev, Atanas Botev, Dunja Jankovic, Kaja Avbersek, Gianluca Constantini, Matei Branea, Maja Veselinovic, Mile Nicevski, Toni Dimitrov).

[https://www.facebook.com/PersonalFuturismPublicPolitics?ref\\_type=bookmark](https://www.facebook.com/PersonalFuturismPublicPolitics?ref_type=bookmark)

### **Comic Book-Anthology (Artist):**

*Zhenski strip na Balkanu/Female Comics on Balkan*, anthology, Fibra, Zagreb, Croatia, 2010: [www.fibra.hr/www.stripovi.com](http://www.fibra.hr/www.stripovi.com), editors: Irena Jukic Pranjic and Marko Sunjic.

### **Magazines (Artist):**

*Makedonska Riznica*, Comics presentation by Ivanka Apostolova, editor: Aleksandar Stevanov, E-magazine, Skopje, Macedonia, no.24, July, 2014.

[http://issuu.com/makedonska\\_riznica/docs/makedonska\\_riznica\\_24](http://issuu.com/makedonska_riznica/docs/makedonska_riznica_24)

Ligatura Calendar, *Female Comics From Central Europe*, Centrala, Poznan, Poland, 2010: [www.centrala.org.pl](http://www.centrala.org.pl); [www.ligatura.eu](http://www.ligatura.eu)

Portal Eastern European Comics, 2010:

<http://www.easterneuropeancomics.com/macedonia/ivanka-apostolova/>

Apostolova presented by Croatian comic artist Irena Jukic Pranjic, 2009:

[http://irenajukicpranjic.blogspot.com/2009\\_07\\_01\\_archive.html](http://irenajukicpranjic.blogspot.com/2009_07_01_archive.html)

### **Magazines:**

**Fumetti d'oltremare, Sustainable Life**, Fanzine, Vasto, Italy:

Comic: *Comicquake*, july, 2009

**Kontejner**, Ljubljana, Slovenia ([www.kontejnermag.com](http://www.kontejnermag.com)):

Comic: *To Dead-En A Nerve*, no. 005/2007

**Apokalipsa**, Ljubljana, Slovenia:

Comic: *This Woman is suffering*, no. 106/2006

**D Magazine** (*D is for drawing*), magazine-project by Yane Calovski (editor and publisher), Holland, Germany, Macedonia (publishers: Revolver, Veenman Publishers/Gijs Stork):

Comics, drawings, no: 1/2006/2005

**Art Republika**, Magazine for Culture and the Art of Living, Arti Fakti, Skopje, Macedonia:

Comics, no: 6/2006

Comics, no: 1/2005

**Xen**, comic book, Studioosem, Ljubljana, Slovenia:

Vignette, december, 2004

**Gledališki list** - Mestno gledališče Ljubljana, *Bolje tič v roki kot tat na strehi*, theater comic, Slovenia, december/2004

**www.com-x2.com/main./factory/section**, comic: *Dirty Tricks with Rok and Mrs. Baskar*, Czech Republic, 11.10.2004

<http://imaginingourselves.imow.org/pb/Profile.aspx?id=11&lang=1&storyid=65>

comic: *Dirty Tricks with Rok and Mrs. Baskar*, San Francisco, USA, 2004

**Apokalipsa**, magazine for life and culture, Ljubljana, Slovenia:

*Manifesto for living abroad*, no: 70/2003

Haiku comics: *Haiku kimono*, no: 63/64/65/2003

**Milk&Wodka**, continental comic book, Swiss:

*CV from Slovenia*, no: 4/2003

**La Flaca**, revista des estudiantes, Ljubljana, Slovenia:

*Invisible threat*, no: 4/5, may/2003

**Stripburger**, comic's magazine, Ljubljana, Slovenia:

*Self portray*, no: 34/2002

**Cool Strip**, Anthology, Prilep, Macedonia:

*Comic poster*, no: 2/2002

**T 3, 40**, fanzine, Domžale, Slovenia + **Feminus stripus-Human Rights/ Woman Rights**, comic's edition, Vršac, Serbia:

*Love comic episode no: 0* - no: 9/2002, no: 1/2002

**Kerosene Rivoluzione** - comic's newspaper, Bologna, Italy:

*Anti (War Comic) Dairy*, Novembre/Dicembre 2001

**Stripburger** - comic's magazine, Ljubljana, Slovenia:

*The metaphysics of self-criticism*, no: 29/2001

**Studentski Zbor**- student magazine, Skopje, Macedonia:

Comics:

*I am happy, very happy...*- 23.05.2001

*On a comic menu I have: ...* - 11.04.2001

*Anti comic (unfinished comic)* - 28.03.2001

*Hey you!* - 19.03.2001

*Daddy* - 28.02.2001

*Love comic episode no: 2: Still life in the cold room; Love resume* - 15.02.2001

*My reverie is a portray of you* - 27.12.2000

*Perfume Aldis Gedutis* - 15.12.2000

*Festival* - 29.11.2000

*Love comic episode no: 3: In the bed* - 15.11.2000

*Love comic episode no: 4: Pod Turnom št: 4* - 18.10.2000

*Federalist* - 2.10.2000

*Comic surgery* - 24.05.2000

*Instead of sun there is a woman rising* - 26.04.2000

*Boring?* - 1.03.2000

*Little Lizha Brikolazh* - 20.10.1999

*Excuse my feminism* - 26.05.1999

*Claustrophobic blouse* - 14.04.1999

*Finger* - 17.03.1999

*Do you love her?* - 9.12.1998

*You have the eyes of a bitter devil* - 11.11.1998

*And the murderer is wondering* - 14.10.1998

*T* - 1.10.1998

*Mammy* - 13.15.1998

**Lift**, comic magazine, Skopje, Macedonia,  
<http://www.templum.com.mk/lift/angliski/ivanka.htm>:

*I hate you dominant women - said the Minotaurus*; Textual comic; Comic interview: *Censored swallowing*, no: 11/1999/2000

*A letter from 1929; A Pathetically Comic; The Terrible Zhazhil Ugurau; At 15.30h I Met the Man Of My Life*, no: 2/1997

**Grad**, magazine for rock`n`roll and urban culture, Skopje, Macedonia:

*Story from the 462nd line on the face*, autumn/2000

**ZOFA**, student's magazine, Ljubljana, Slovenia:

*Love comic episode no: 1: On a gender barricades demonstrators are carrying unusual pamphlet*, No: 18/19, October/November/2000

### **Mentor/comic workshops:**

#### **2004**

*Jungle in the city*, drawing and cutting, making animal hanging installations, children

workshop, organizers: SEZAM, Poetova Pot;

*Comic strip broches*, children workshop, Emonska Promenada, Trnfest, Organizers: Hiša

Otrok in Mladine, Ljubljana, Slovenia

*Coloured in film*, comics on blank film tapes, Stuart Famul - School of Applied Arts, Fužinski Grad, Ljubljana, Slovenia.

#### **2003**

*Mačkov kotiček: Comic strip broches*, open air workshop; Ljubljana, organizer: SEZAM, Slovenia

*Phantom in my head*, creative workshop: Collage comics, deconstructing comics, mix media comics, Stuart Famul - School of Applied Arts, Fužinski Grad, Ljubljana, Slovenia

#### **2002**

*Collage comics and deconstructing comics*, Youth Centre Brežice, Festival: The Art of Tolerance, Brežice, Slovenia

*Collage comics and comic jewelry workshop*, Stuart Famul - School of Applied Arts, Fužinski Grad, Ljubljana, Slovenia

### **Comic workshops (Artist/Participant):**

#### **2005**

- (September) Artist/Participant - Comic workshop: Creating comic strip script, artist/mentor: Lionel Tran, Ambre, Organizers: Strip Core/Stripburger, Ljubljana, Slovenia.

### 2003

- (Oktober) Artist/Participant - Puppets workshop, artist: Dame Darcy, Organizers: 8. Festival City of Women/Mesto Zhensk, Ljubljana, Slovenia.
- (June) Artist/Participant - Comic posters workshop, artist: Humbert Christian Droz, Organizers: Stripburger, Break 2.2 Festival, Ljubljana, Slovenia.
- (April) Artist/Participant - Workshop: Avant-cinematografique animation, artist: Remy, Organizers: Stripburger, French cultural centre Charles Nodier, Ljubljana, Slovenia.

### 2002

- (Oktober) Artist/Participant - Workshop: Documentary comics, artist: Dominique Goblet, Organizers: 7. Festival City of Women/Mesto Zhensk, Ljubljana, Slovenia.

### 2000

- (Oktober) Artist/Participant - Workshop: Comic Diary, artist: Helena Klakocar, Organizers: 5. International Festival of Contemporary Arts City of Women/Mesto Zhensk, Galerija Faronika, Ljubljana, Slovenia.



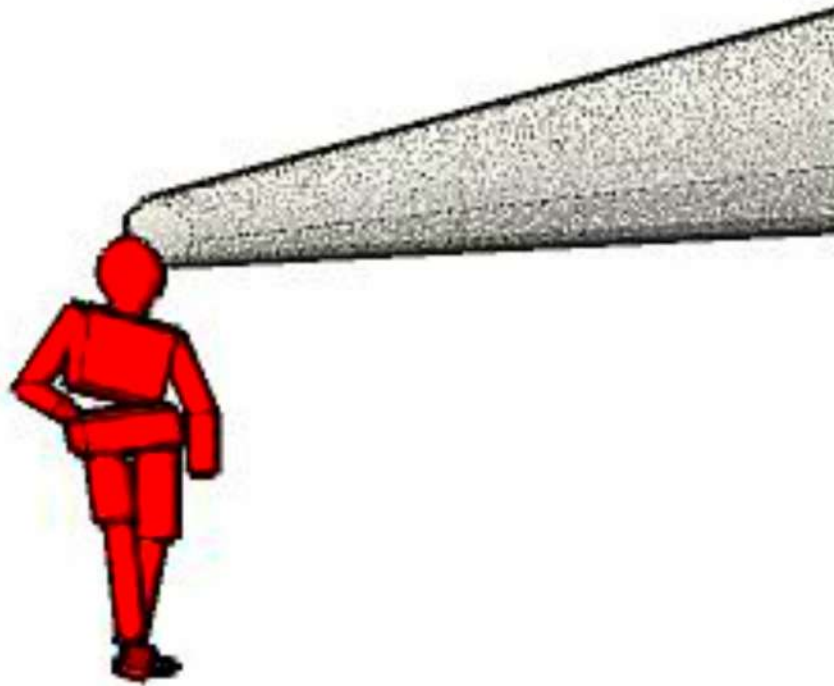

**ISBN 978-608-4912-02-6**